



2026

ENJOY RIDING
WITH YUEMAI



东莞市科拓电子科技有限公司
Dongguan Ketuo Electronic Technology Co., Ltd.

Product Catalogue

| | |
|-------------------------|--------|
| 01 Cycling Phone Holder | 04~66 |
| 02 Cycling Charger | 68~81 |
| 03 Phone Holder for Car | 83~84 |
| 04 BT Helmet Earphone | 86-87 |
| 05 Camera Holder | 89 |
| 06 Bottle Holder | 91 |
| 07 Accessories | 93~116 |



01

Cycling Phone Holder

Note for the Letters in Model No. :

A: Black, non-charging handlebar installation

B: Black, non-charging rearview mirror installation

C: Black, charging handlebar installation

D: Black, charging rearview mirror installation

KT-37

Bluetooth speaker+charging+holder 3-in-1 multifunctional Bluetooth Speaker Holder



- Bluetooth chip 5.3, low power consumption, fast and stable connection
- Stereo full frequency surround 40mm large-sized frequency drive unit, high-definition HIFI sound quality after connected to Bluetooth
- Supports TF card playback, up to 64GB 
- Adjust the width of the left adjustment knob, and fix it with one click using the right locking key
- Quick release design, semi enclosed camera without obstruction
- The connected horizontal bar rotates 360°, and the horizontal and vertical screens can be adjusted freely
- Sunscreen cap/camera stand expansion
- Shock absorption panel+thickened silicone on both sides+upgraded shock-absorbing block, earthquake and fall resistant
- TYPE C port+shrink cable (pulled out about 35cm) integrated, convenient for charging
- 1.4-meter power cord length+5A fuse

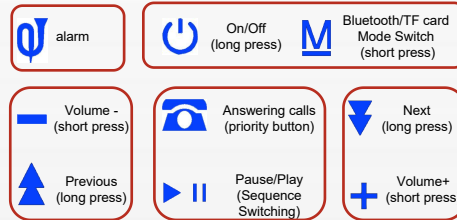
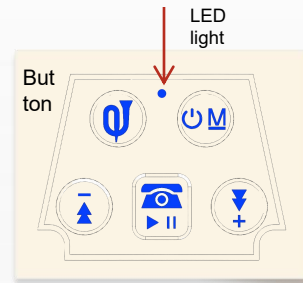

Bluetooth low power consumption version: 5.3

Speaker: 40mm full frequency surround sound

Support TF card playback, built-in microphone head

Main materials: PA66+30% GF+silicone+stainless steel

Installation method: crossbar/handlebar/rearview mirror/thin tube clamp

Horizontal bar diameter: 19-33mm

Mobile phone width: 68-94mm thickness: 16mm max length: 120-200mm

Support: motorcycles, tricycles, electric bicycles, bicycles, handcarts, etc

- Input: DC10-80V Output: TYPE C(Shrinkable cable35cm) : 5V/3A
- BT Input: 5V Speaker Power: 5W max Trumpet: 3Ω

1 pcs/gift box

Weight: g

Box Size:mm

Packing: pcs / carton

Carton size: cm

Carton GW: kg

YF-353-A/B

Mini phone mount with locking switch

Material: PA66+30%GF+Silicone+Stainless Steel

Installation method: handlebar/mirror/cross bar

Handlebar tube diameter: 12-33mm

Crossbar tube diameter: 19-33mm

Mirror hole diameter: 10mm

Suitable Phone width: 64-90mm Thickness: 12.5mm (max)

Length: 120-200mm

Application: motorcycles, tricycles, e-bicycles, bicycles, handcars, etc



YF-353A-01
Φ25mm Ball Handlebar



YF-353B-01
Φ25mm Ball Mirrorbase



YF-353A-02
Φ17mm Ball Handlebar



YF-353B-02
Φ17mm Ball Mirrorbase

- Height adjustment fixed rod, suitable for bumpy roads
- One-handed quick retrieval and placement of the phone
- Adjust the width with the left knob, and lock it in place with the right button
- Stainless steel downrod mechanical feel push-pull stroke, locking switch with dual safety
- The anti-theft knob on the arms can adjust the angle but cannot remove the holder
- Omni-directional rotation, adjustable in any orientation
- Adjustable length/width, does not block the camera
- Sun hat/camera mount extension
- Four sets of upgraded shockproof blocks, earthquake-resistant and drop-proof
- Thickened silicone protection

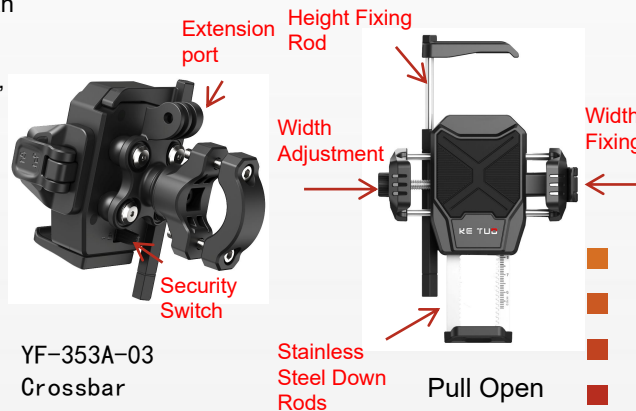

YF-353A-03
Crossbar

1 pcs/gift box
Weight: g
Box Size: 175*100*90mm

Packing: 50 pcs / carton
Carton size: 52*37*47.50 cm
Carton GW: kg

YF-353-C/D

Mini phone mount with locking switch

Material: PA66+30%GF+Silicone+Stainless Steel

Installation method: handlebar/mirror/cross bar

Handlebar tube diameter: 12-33mm

Crossbar tube diameter: 19-33mm

Mirror hole diameter: 10mm

Suitable Phone width: 64-90mm Thickness: 12.5mm (max)

Length: 120-200mm

Application: motorcycles, tricycles, e-bicycles, bicycles, handcarts, etc



YF-353C-01
Φ25mm Ball
Handlebar



YF-353D-01
Φ25mm Ball
Mirrorbase



YF-353C-02
Φ17mm Ball
Handlebar



YF-353D-02
Φ17mm Ball
Mirrorbase



YF-353C-03
Crossbar

Safety
lock for
pull-
down
rods



TYPE C Port
Waterproof
and Rainproof
cover

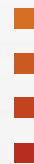

Charging Info: Input: DC 10V-24V

Output: Wireless 15W TYPE C 33W

- Height adjustment fixed rod, suitable for bumpy roads
- One-handed quick retrieval and placement of the phone
- Adjust the width with the left knob, and lock it in place with the right button
- Stainless steel downrod mechanical feel push-pull stroke, locking switch with dual safety
- The anti-theft knob on the arms can adjust the angle but cannot remove the holder
- Omni-directional rotation, adjustable in any orientation
- Adjustable length/width, does not block the camera
- Sun hat/camera mount extension
- Four sets of upgraded shockproof blocks, earthquake-resistant and drop-proof
- Thickened silicone protection
- 1.4m cable with SAE socket and 5A fuse

1 pcs/gift box

Weight: g

Box Size: 175*100*90mm

Packing: 50 pcs / carton

Carton size: 52*37*47.50 cm

Carton GW: kg

YF-352-A/B

Three proof dedicated mobile phone holder with safety lock

Main material: PA66+30% GF

Installation method: handlebar/rearview mirror/crossbar

Handlebar clamping diameter: 19-33mm

Crossbar diameter: 19-33mm

Rearview mirror aperture: 10mm

Phone width: 62-85mm Phone thickness: 36mm (max) Phone length: 132-190mm

Applicable vehicle models: motorcycles, tricycles, electric bicycles, bicycles, handcarts, etc

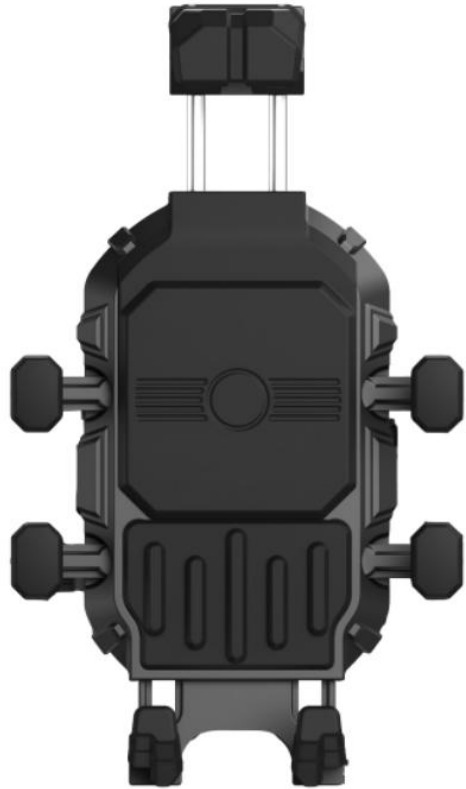

YF-352A-01
Φ25mm Ball
Handlebar



YF-352B-01
Φ25mm Ball
Mirrorbase



YF-352A-02
Crossbar

- Exclusive for Three proof mobile phone, widened in phone sizes
- One click secure lock to fix the phone
- Stainless steel rod adjustment length
- Anti pressure button groove design on the four claws
- Anti theft clip arm design
- 4 sets of cushion airbags and shock absorbers
- Seven claw embedded soft silicone foot pad protection
- Anti slip thickened silicone protection
- Waterproof sun hat expansion

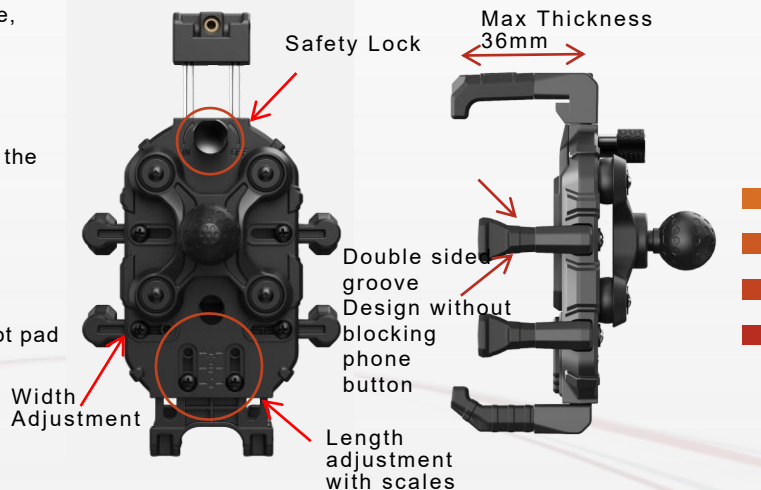

1 pcs/box
Weight: g
Box Size: 187*113*126mm

Packing: 40 pcs / carton
Carton size: 60*39.7*52.5cm
Carton GW: kg

YF-349-A/B

Quick Release shock-absorbing charging phone holder

Main Material: ABS+PC

Installation method: handlebar/rearview mirror/crossbar

Handlebar diameter: 19-33mm crossbar diameter: 19-33mm

rearview mirror aperture: 10mm

Mobile phone width: 60-90mm length: 140-190mm max

thickness: 22mm

Applicable vehicle models: motorcycles, tricycles, electric bicycles, bicycles, handcarts, etc



YF-349A-01
Φ25mm Ball Handlebar



YF-349B-01
Φ25mm Ball Mirrorbase



YF-349A-02
Crossbar

- Shock absorption panel design, fully equipped with shock-absorbing silicone pads
- Left safety lock buckle locking design, stable performance in various road conditions
- Quick access and quick release design, gently push upwards, take and release in one second
- Four corner protected, anti fall design
- The main body is made of reinforced nylon material, which has high strength and resistance to harsh environments
- Independent shock absorber block design
- Support sun hat and camera expansion

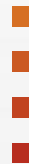

1 pcs/box
Weight: g
Box Size: 187*113*126mm

Packing: 40 pcs / carton
Carton size: 60*39.7*52.5cm
Carton GW: kg

YF-349-C/D

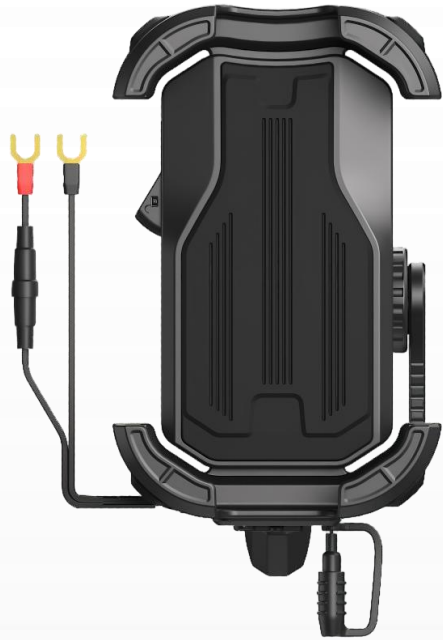

YF-349C-01
Φ25mm Ball Handlebar



YF-349D-01
Φ25mm Ball Mirror



YF-349C-02
Crossbar



Quick Release shock-absorbing charging phone holder

Main Material: ABS+PC

Installation method: handlebar/rearview mirror/crossbar

Handlebar diameter: 19-33mm crossbar diameter: 19-33mm rearview mirror aperture: 10mm

Mobile phone width: 60-90mm length: 140-190mm max thickness: 22mm

Applicable vehicle models: motorcycles, tricycles, electric bicycles, bicycles, handcarts, etc

- Input: DC10-80V Output: TYPE C+USB: 5V/3A

- Shock absorption panel design, fully equipped with shock-absorbing silicone pads
- Left safety lock buckle locking design, stable performance in various road conditions
- Quick access and quick release design, gently push upwards, take and release in one second
- Four corner protected, anti fall design
- The main body is made of reinforced nylon material, which has high strength and resistance to harsh environments
- Independent shock absorber block design
- Support sun hat and camera expansion
- Wide voltage input of 10-80V, stable output
- Charging cable 1.4m+5A fuse
- USB A+TYPEC dual port output
- Power button+LED indicator light
- TYPE C port+shrink cable integrated, convenient for charging

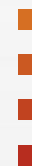

1 pcs/box
Weight: g
Box Size:187*113*126mm

Packing: 40 pcs / carton
Carton size: 60*39.7*52.5cm
Carton GW: kg

YF-338-A/B

• Patent ID : Pending

7-claws Phone Mount with Security Key

Main material: PA66+30%GF+stainless steel
 Color: Black
 Installation method: Handlebar/Mirrorbase/Extentionbar
 Handlebar diameter: 19-33mm
 Extention bar diameter: 19-33mm
 Mirror hole diameter: 10mm
 Phone clamp width: 62~85mm
 Phone clamp length: 132-190mm
 Maximum phone thickness for clamping: <15mm
 Application: motorcycles, tricycles, electric bicycles, bicycles, handcarts, etc

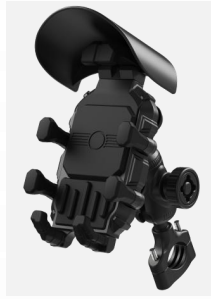
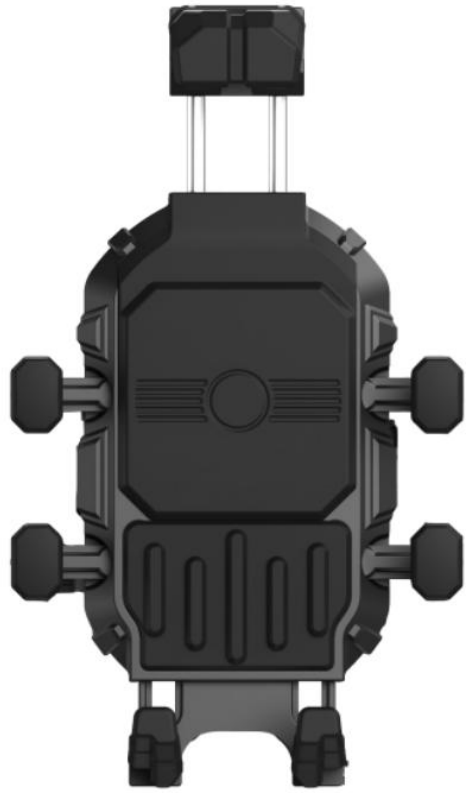

YF-338A-01
Φ25mm Handlebar



YF-338B-01
Φ25mm Mirror



YF-338A-02
Φ17mm Handlebar

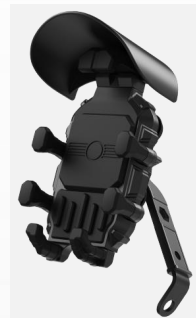

YF-338B-02
Φ17mm Mirror



YF-338A-03
Extension bar

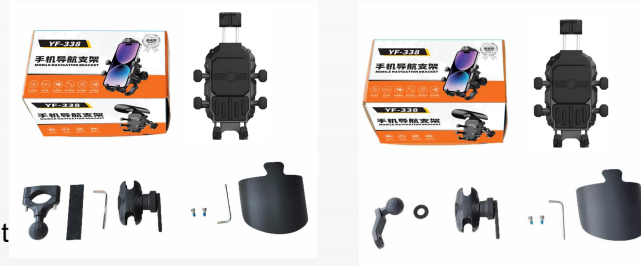
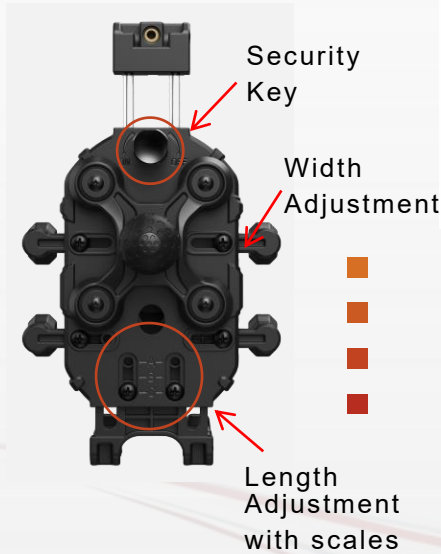

A1 Handlebar

B1 Mirror

1 pcs/gift box
 Weight: 578g
 Box Size:187*113*106mm

Packing: 40 pcs / carton
 Carton size: 59*41.5*43.5cm
 Carton GW: 24.6kg

- One-touch secure lock for mobile phones
- The lifting mechanism is flexible in both directions without obstructing the camera
- Aluminum alloy base, stainless steel support rod
- Anti-theft clamp design
- Four sets of shock-absorbing dampener
- Seven-claw embedded soft silicone foot pad protection
- Non-slip thickened silicone protection
- Waterproof sun hat expansion
- Suitable for multi phone models, 7 installation bases available

YF-338-C/D

• Patent ID : Pending

7-claws Phone Mount with Security Key

Main material: PA66+30%GF+stainless steel
 Color: Black
 Installation method: Handlebar/Mirrorbase/Extentionbar
 Handlebar diameter: 19-33mm
 Extention bar diameter: 19-33mm
 Mirror hole diameter: 10mm
 Phone clamp width: 62~85mm
 Phone clamp length: 132-190mm
 Maximum phone thickness for clamping: <15mm
 Application: motorcycles, tricycles, electric bicycles, bicycles, handcars, etc

* Charging: Input: DC 12V-24V

Output: TYPE-C 30W Wireless: 15W

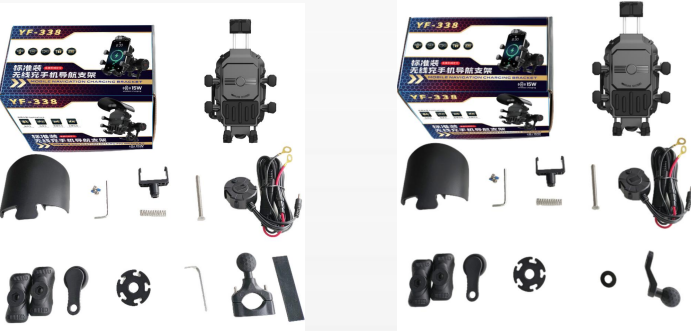

C1 Handlebar

D1 Mirror

1pcs/gift box
 Weight: 744g
 Box Size: 187*113*126mm

Packing: 40 pcs / carton
 Carton size: 60*39.7*52.5cm
 Carton GW: 32kg



YF-338C-01
 Φ25mm Handlebar

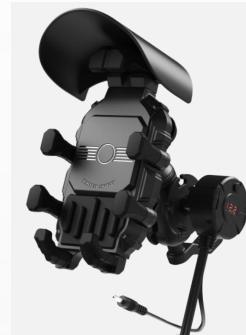

External charging host

YF-338D-01
 Φ25mm Mirror

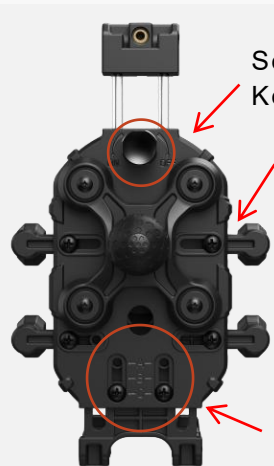

Security Key

Width Adjustment

Length Adjustment with scales

- One-touch secure lock for mobile phones
- The lifting mechanism is flexible in both directions without obstructing the camera
- Aluminum alloy base, stainless steel support rod
- Anti-theft clamp design
- Four sets of shock-absorbing dampener
- Seven-claw embedded soft silicone foot pad protection
- Non-slip thickened silicone protection
- Waterproof sun hat expansion
- Suitable for multi phone models, 7 installation bases available
- 1.5m extension + SAE+5A fuse
- The length can be adjusted with scale markings, making it easy to align the wireless charging center

YF-348-A/B

• Patent ID : Pending

7-claws Phone Mount with Go-pro Connection

Main material: PA66+30%GF+stainless steel
 Color: Black
 Installation method: Handlebar/Mirrorbase/Extentionbar
 Handlebar diameter: 19-33mm
 Extention bar diameter: 19-33mm
 Mirror hole diameter: 10mm
 Phone clamp width: 67~90mm
 Phone clamp length: 136-200mm
 Maximum phone thickness for clamping: <25mm
 Application: motorcycles, tricycles, electric bicycles, bicycles, handcars, etc



YF-348A-01
Φ25mm Handlebar



YF-348B-01
Φ25mm Mirror



YF-348A-02
Φ17mm Handlebar



YF-348B-02
Φ17mm Mirror

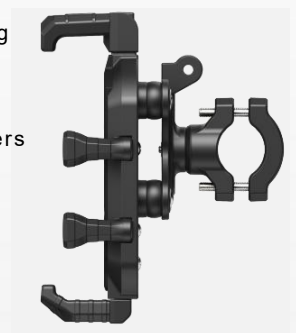

YF-348A-03
Extension bar

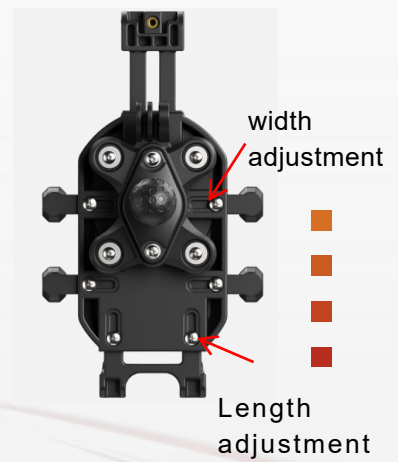

- Flexible up and down lifting, without blocking the camera
- Anti theft clip design
- 4 sets of cushion airbags and shock absorbers
- Seven claw embedded soft silicone foot pad protection
- Anti slip thickened silicone protection
- Waterproof sun hat and camera bracket expansion
- Suitable for multi phone models, 7 installation bases available



A1 Handlebar

B1 Mirror

1pcs/gift box
 Weight: 630g
 Box Size: 187*113*126mm
 Packing: 40 pcs / carton
 Carton size: 60*39.5*52.5cm
 Carton GW: 26.6kg

YF-348-C/D

• Patent ID : Pending

7-claws Phone Mount with Go-pro Connection



- Flexible up and down lifting, without blocking the camera
- Anti theft clip design
- 4 sets of cushion airbags and shock absorbers
- Seven claw embedded soft silicone foot pad protection
- Anti slip thickened silicone protection
- Waterproof sun hat and camera bracket expansion
- Suitable for multi phone models, 7 installation bases available
- 1.5m extension + SAE+5A fuse
- The length can be adjusted, making it easy to align the wireless charging center

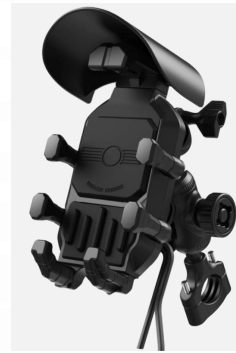

YF-348C-01
Φ25mm Handlebar



YF-348D-01
Φ25mm Mirror

Built-in Charging PCBA



width adjustment

length adjustment

Main material: PA66+30%GF+stainless steel
 Color: Black
 Installation method: Handlebar/Mirrorbase/Extentionbar
 Handlebar diameter: 19-33mm
 Extention bar diameter: 19-33mm
 Mirror hole diameter: 10mm
 Phone clamp width: 67~90mm
 Phone clamp length: 136-200mm
 Maximum phone thickness for clamping: <22mm
 Application: motorcycles, tricycles, electric bicycles, bicycles, handcarts, etc

* Charging: Input: DC 12V-24V

Output: USB 18W TYPE-C 30W Wireless: 15W



C1 handlebar with charging



D1 mirror with charging

1pcs/gift box
 Weight: 721.5g
 Box Size: 187*113*126mm

Packing: 40 pcs / carton
 Carton size: 60*39.7*52.5cm
 Carton GW: 31kg

YF-343-A/B

• Patent ID : Pending

One-touch automatic extendable phone mount

Main material: PC+ABS+stainless steel

Color: Black

Installation method: Handlebar/Mirrorbase/Extentionbar

Handlebar diameter: 19-33mm

Extention bar diameter: 18-26mm

Mirror hole diameter: 10mm

Phone clamp width: 64mm~95mm

Phone clamp length: 130-170mm

Maximum phone thickness for clamping: <22mm

Application: motorcycles, tricycles, electric bicycles, bicycles, handcarts, etc

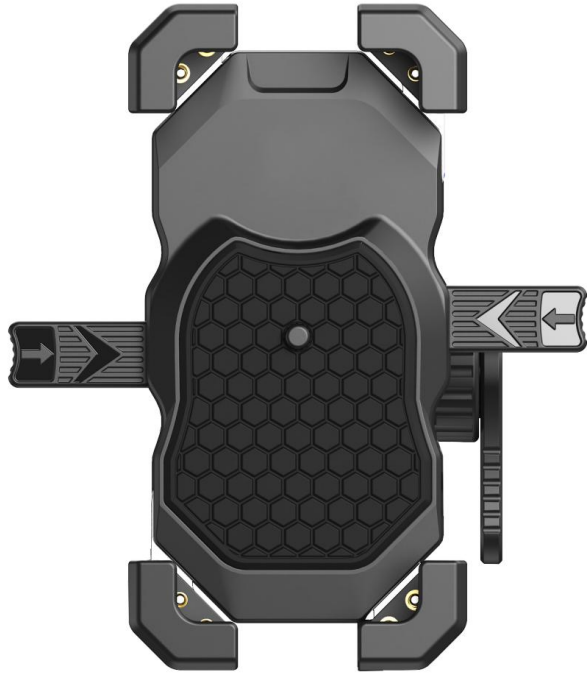

YF-343A-01
Φ25mm Ball Handlebar



YF-343B-01
Φ25mm Ball Mirrorbase



YF-343A-02
Φ17mm Ball Handlebar



YF-343B-02
Φ17mm Ball Mirrorbase

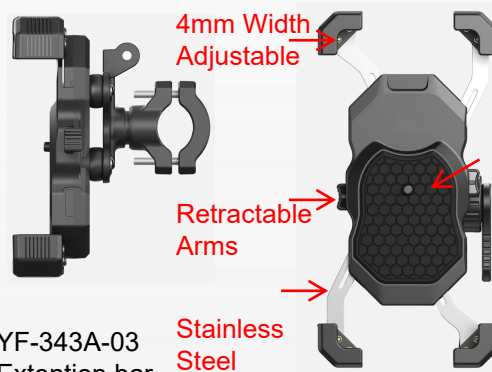

YF-343A-03
Extention bar

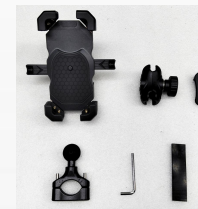

YF-343A-01
Φ25mm Ball
Handlebar



YF-343B-02
Φ17mm Ball
Mirrorbase

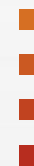

1pcs/box
NW: g
GW: g
Main body size: mm
Box Size: 180X135X106mmmm

Packing: pcs /carton
Carton size: cm
Carton GW: kg

- Damping panel design, with high-elasticity shock-absorbing rubber installed at the four corners
- Independent air suspension with four-corner shock absorption
- Slip-proof rubber pad + silicone anti-slip dual phone protection
- Rotating mechanical positioning, 360° rotation design
- One-click automatic extension and retraction, one-handed push and press on both sides, instant access and release
- Gently push the phone upward and release it to lock automatically
- Comprehensive compatibility for a wider range of mobile phones
- Quickly adapt to mobile phones with one-handed operation
- Suitable for all terrains

YF-343-C/D

• Patent ID : Pending

One-touch automatic extendable phone mount with charging

Main material: PC+ABS+stainless steel

Color: Black

Installation method: Handlebar/Mirrorbase/Extentionbar

Handlebar diameter: 19-33mm

Extention bar diameter: 18-26mm

Mirror hole diameter: 10mm

Phone clamp width: 64mm~95mm

Phone clamp length: 130-170mm

Maximum phone thickness for clamping: <22mm

Application: motorcycles, tricycles, electric bicycles, bicycles, handcarts, etc

Charging instructions: Input DC 12V-24V

Output TYPE C: 33W (max) (35mm extention cable)

USB A: 18W (max)

Wireless charging: 15W (max)



YF-343C-01
Φ25mm Ball Handlebar



YF-343C-03
Extension Bar

1pcs/box
NW: g
GW: g
Main body size: mm
Box Size: 180X135X106mm

Packing: pcs /carton
Carton size: cm
Carton GW: kg



YF-343C-01
Φ25mm Ball Handlebar



YF-343D-01
Φ25mm Ball Mirrorbase



YF-343C-02
Φ17mm Ball Handlebar



YF-343D-02
Φ17mm Ball Mirrorbase



YF-343C-03
Extension Bar

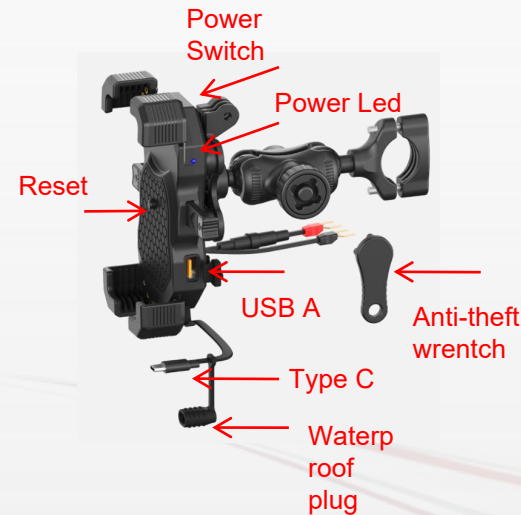
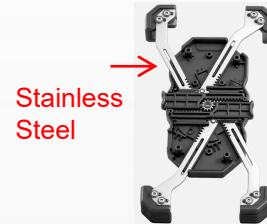

- Shock absorption panel design, equipped with high elasticity shock-absorbing rubber at the four corners
- Independent airbag four corner shock absorber
- Anti slip pad+anti slip silicone dual phone protection
- Rotating mechanical positioning, 360° rotation design
- One click automatic extension and retraction, one hand push and press on both sides, take and place in seconds
- Push the phone upwards lightly, release it and it will automatically lock
- Fully compatible with a wider range of mobile phones
- Quick adaptation to mobile phones, one handed operation
- USB+TYPE C+wireless charging three ports, independent fast charging
- Independent power switch+indicator
- TYPEC extention wire length 35cm+waterproof cover protection
- Power cord length 150cm with SAE+5A fuse

YF-342-A/B

• Patent ID : Pending

Five-cornered Quick Release Phone Mount

Main material: PC+ABS+stainless steel

Color: Black

Installation method: Handlebar/Mirrorbase/Extentionbar

Handlebar diameter: 19-33mm

Extention bar diameter: 18-26mm

Mirror hole diameter: 10mm

Phone clamp width: 66~90mm

Phone clamp length: 120-220mm

Maximum phone thickness for clamping: <24mm

Application: motorcycles, tricycles, electric bicycles, bicycles, handcarts, etc



YF-342A-01
Φ25mm Ball Handlebar



YF-342B-01
Φ25mm Ball Mirrorbase



YF-342A-02
Extension bar

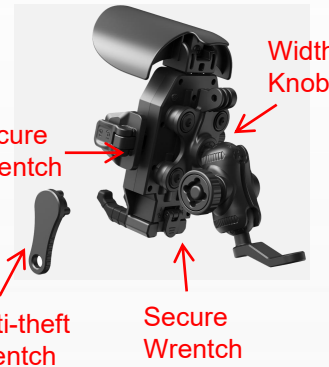

- Shock absorption panel design, hexagonal full package configuration with high elasticity shock-absorbing rubber
- Independent airbag four corner shock absorber
- Anti slip pad+anti slip silicone dual phone protection
- Four corner locking+one click locking, safe and stable
- Fully compatible with a wider range of mobile phones
- Rotating mechanical positioning, 360° rotation design
- Push and pull with one hand, pick and place in seconds, gently push upwards, and automatically close when released
- Quick adaptation to mobile phones, one handed operation
- Suitable for various road conditions



YF-342A-01
Φ25mm Ball
Handlebar



YF-342A-02
Extension bar

1pcs/box
NW: g
GW: g
Main body size: mm
Box Size: 187*113*126mm

Packing: 40 pcs / carton
Carton size: 60*39.7*52.5cm
Carton GW: kg

YF-342-C/D

• Patent ID : Pending

Five-cornered Quick Release Phone Mount with Charging



YF-342C-01
Φ25mm Ball Handlebar



YF-342D-01
Φ25mm Ball Mirrorbase



YF-342C-02
Extension Bar

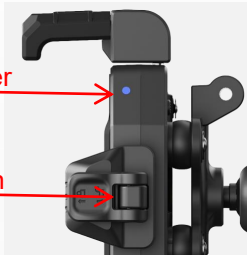

- Shock absorption panel design, hexagonal full package configuration with high elasticity shock-absorbing rubber
- Independent airbag four corner shock absorber
- Anti slip pad+anti slip silicone dual phone protection
- Four corner locking+one click locking, safe and stable
- Fully compatible with a wider range of mobile phones
- Rotating mechanical positioning, 360° rotation design
- Push and pull with one hand, pick and place in seconds, gently push upwards, and automatically close when released
- Quick adaptation to mobile phones, one handed operation
- USB+TYPE C+wireless charging three ports, independent fast charging
- Independent power switch+indicator
- TYPEC extension wire length 35cm+waterproof cover protection
- Power cord length 150cm with SAE+5A fuse

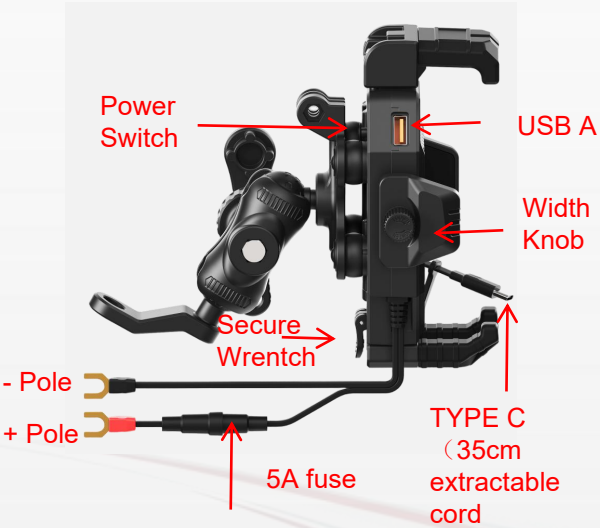

Main material: PC+ABS+stainless steel

Color: Black

Installation method: Handlebar/Mirrorbase/Extentionbar

Handlebar diameter: 19-33mm

Extention bar diameter: 18-26mm

Mirror hole diameter: 10mm

Phone clamp width: 66~90mm

Phone clamp length: 120-220mm

Maximum phone thickness for clamping: <24mm

Application: motorcycles, tricycles, electric bicycles, bicycles, handcars, etc

Charging instructions: Input DC 12V-24V

Output TYPE C: 33W (max) (35mm extension cable)

USB A: 18W (max)

Wireless charging: 15W (max)



YF-342C-01
Φ25mm Ball Handlebar

1pcs/box
NW: g
GW: g
Main body size: mm
Box Size: 187*113*126mm



YF-342C-02
Extension Bar

Packing: 40 pcs / carton
Carton size: 60*39.7*52.5cm
Carton GW: kg

YF-339-A/B

• Patent ID : Pending

X Grip Cycling phone holder

Material: Stainless Steel +PA66+30%GF

Color: Black

Suitable Phone Size: 3.5 - 6 inch

Mounting Type: Handlebar / Mirrorbase

Pipe clamp dia.: 22mm Mirrorhole dia.: 10mm



- Slip-resistant rubber pad + double anti-slip silicone phone protection
- Four-corner locking + anti-drop fixed net with multiple positioning, secure and stable
- Completely compatible with a wider range of mobile phones
- Tool-free 360° rotation, switch between horizontal and vertical screens at will
- Unobstructed design, easy to operate, does not block the front and rear cameras volume buttons, charging port, or headphone jack
- Quick-release structure, lightweight and flexible
- Dual-port charging with USB and TYPE C



YF-339-A Handlebar



YF-339-B Mirrorbase

1pcs/gift box
 Net Weight: g
 GW: g
 Main body size: 55*115*50mm
 Box Size: 130*95*55mm

Packing: 100pcs /carton
 Carton size: 59*28*50cm
 Carton GW: kg



YF-339-C/D

• Patent ID : Pending

X Grip Cycling phone holder

Material: Stainless Steel +PA66+30%GF

Color: Black

Suitable Phone Size: 3.5 - 6 inch

Mounting Type: Handlebar / Mirrorbase

Pipe clamp dia.: 22mm Mirrorhole dia.: 10mm

Input: DC 10V-24V

Output: USB+TYPE C: 5V 2.4A



YF-339-C charging handlebar



YF-339-D charging mirrorbase

1pcs/gift box
 Net Weight: g
 GW: g
 Main body size: 55*115*50mm
 Box Size: 130*95*55mm

Packing: 100pcs /carton
 Carton size: 59*28*50cm
 Carton GW: kg



- Slip-resistant rubber pad + double anti-slip silicone phone protection
- Four-corner locking + anti-drop fixed net with multiple positioning, secure and stable
- Completely compatible with a wider range of mobile phones
- Tool-free 360° rotation, switch between horizontal and vertical screens at will
- Unobstructed design, easy to operate, does not block the front and rear cameras volume buttons, charging port, or headphone jack
- Quick-release structure, lightweight and flexible
- Dual-port charging with USB and TYPE C

YF-336L

• Patent ID : Pending

Cycling phone holder

Material: ABS+PC

Color: Black / Red / Customized

Mounting Type: Handlebar / Mirrorbase

Pipe clamp dia.: 12-33mm Mirrorhole dia.: 10mm

Phone width: 70-90mm length: 140-180mm max thickness: 14mm

Support: Motorcycle, Tricycle, E-bike, Bicycle

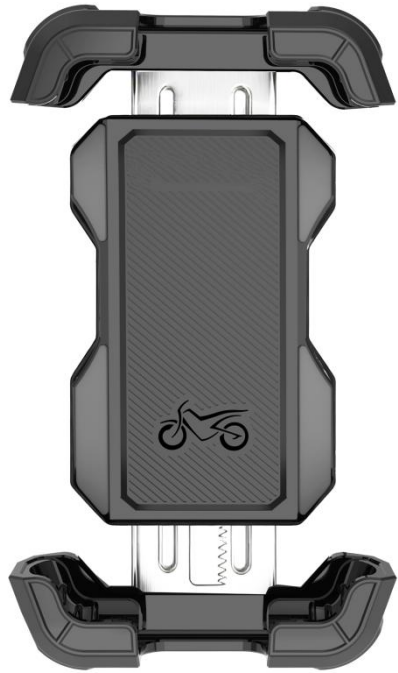

YF-336L-A01
25mm Handlebar



YF-336L-B01
25mm Mirrorbase



YF-336L-A02
17mm Handlebar



YF-336L-B01
17mm Mirrorbase

- Built in aluminum alloy structure
- Shock absorption panel design, fully equipped with shock-absorbing silicone pads
- Back safety lock buckle locking design, more stable with shaking
- Quick access and quick release design, gently push down, take and release in one second
- Bracket panel with shock-absorbing silicone gasket
- Bidirectional adjustment, not only flexible speed matching, but also stable and strong automatic tightening
- Four corner full package, anti fall design
- The main body is made of reinforced nylon material, which has high strength and resistance to harsh environments
- Fully compatible with a wider range of mobile phones
- Anti-dampener and quick release
- Support sun hat and camera expansion



25mm Handlebar



25mm Mirrorbase

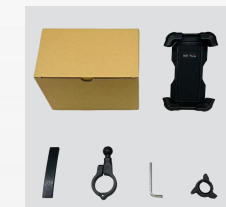

17mm Handlebar

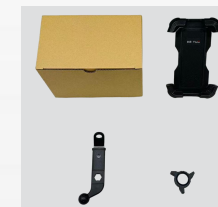

17mm Mirrorbase

1pcs/craft box
Body size: 95*137*60mm
Net Weight: g
GW: 280g
Box Size: 156x102x82mm

Packing: pcs /carton
Carton size: cm
Carton GW: kg



YF-336S

• Patent ID : Pending

Cycling phone holder

Material: ABS+PC

Color: Black / Red / Customized

Mounting Type: Handlebar / Mirrorbase

Pipe clamp dia.: 12-33mm Mirrorhole dia.: 10mm

Phone width: 60-84mm length: 130-170mm max thickness: 14mm

Support: Motorcycle, Tricycle, E-bike, Bicycle

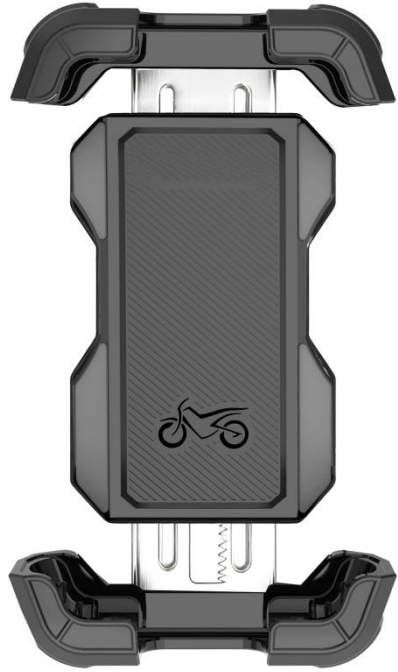

YF-336S-A01
25mm Handlebar



YF-336S-B01
25mm Mirrorbase



YF-336S-A02
17mm Handlebar



YF-336S-B01
17mm Mirrorbase

- Built in aluminum alloy structure
- Shock absorption panel design, fully equipped with shock-absorbing silicone pads
- Back safety lock buckle locking design, more stable with shaking
- Quick access and quick release design, gently push down, take and release in one second
- Bracket panel with shock-absorbing silicone gasket
- Bidirectional adjustment, not only flexible speed matching, but also stable and strong automatic tightening
- Four corner full package, anti fall design
- The main body is made of reinforced nylon material, which has high strength and resistance to harsh environments
- Fully compatible with a wider range of mobile phones
- Two large universal balls rotate 360°, allowing for one handed adjustment of direction and viewing angle
- Support sun hat and camera expansion



25mm Handlebar



25mm Mirrorbase

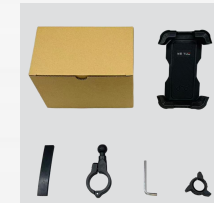

17mm Handlebar

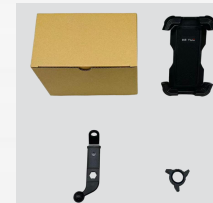

17mm Mirrorbase

1pcs/craft box
Body size: 95*137*60mm
Net Weight: g
GW: g
Box Size: 156x102x82mm

Packing: pcs /carton
Carton size: cm
Carton GW: kg

YF-301 PRO+YF-333

- Patent No.: ZL 2024 3 0433208.7

Cycling phone holder



Material: ABS+PC

Mounting Type: Handlebar / Mirrorbase

Pipe clamp dia.: 19-33mm Mirrorhole dia.: 10mm

Phone width: 60-90mm length: 140-190mm max thickness: 22mm

Support: Motorcycle, Tricycle, E-bike, Bicycle

- Shock absorption panel design, fully equipped with shock-absorbing silicone pads
- Left safety lock buckle locking design, more stable with shaking
- Quick access and quick release design, gently push down, take and release in one second
- Bracket panel with shock-absorbing silicone gasket
- Bidirectional adjustment, not only flexible speed matching, but also stable and strong automatic tightening
- Four corner full package, anti fall design
- The main body is made of reinforced nylon material, which has high strength and resistance to harsh environments
- Fully compatible with a wider range of mobile phones
- Two large universal balls rotate 360 °, allowing for one handed adjustment of direction and viewing angle
- Support sun hat and camera expansion



1pcs/gift box
Net Weight: g
GW: g
Box Size: mm

Packing: pcs /carton
Carton size: cm
Carton GW: kg

YF-301+YF-333

• Patent No.: ZL 2024 3 0433208.7

Cycling phone holder

Material: ABS+PC

Mounting Type: Handlebar / Mirrorbase

Pipe clamp dia.: 12-33mm Mirrorhole dia.: 10mm

Phone width: 60-90mm length: 140-190mm max thickness: 22mm

Support: Motorcycle, Tricycle, E-bike, Bicycle



- Shock absorption panel design, fully equipped with shock-absorbing silicone pads
- Left safety lock buckle locking design, more stable with shaking
- Quick access and quick release design, gently push down, take and release in one second
- Bracket panel with shock-absorbing silicone gasket
- Bidirectional adjustment, not only flexible speed matching, but also stable and strong automatic tightening
- Four corner full package, anti fall design
- The main body is made of reinforced nylon material, which has high strength and resistance to harsh environments
- Fully compatible with a wider range of mobile phones
- Anti-dampener and quick release
- Support sun hat and camera expansion



1pcs/gift box
 Net Weight: g
 GW: g
 Box Size: mm

Packing: pcs /carton
 Carton size: cm
 Carton GW: kg

YF-332

• Patent ID : Pending

Cycling cooling and heat dissipation Mounting

Main material: PA66+30% GF+aluminum alloy
 Cooling plate material: ceramic substrate+bismuth telluride
 Cooling plate size: 23*23*4.2mm
 Cooling power consumption: 5V 1.5A (including fan)
 Installation method: handlebar/rearview mirror
 Installation method: handlebar/rearview mirror
 Pipe diameter: 12-33mm
 Mobile phone width: 66-92mm Length: 120-200mm Maximum thickness: 14mm
 Support: motorcycles, tricycles, electric bicycles, etc.



YF-332-A1



YF-332-A2



YF-332-B1



A+C ports

- Flagship refrigeration new product, high conduction + large area refrigeration, cooling temperature down to 5°C, ice-cold in an instant when turned on
- Professional torque adjustment product width, precision threaded steel, shock-resistant and anti-slip, stable protection
- Symmetrical double-sided silicone clamping, uniform force
- Patented design reinforced base, firmly locks the handlebars, and calmly faces a variety of complex road conditions
- IP68 brand cooling fan, low power consumption, 5000RPM, life span 30000 hours
- Whole Device IP66 level
- Storage under room temperature
- 360° selection, mobile phone viewing angle can be adjusted at will
- Professional design, does not block the camera and charging port, mobile phone is more convenient to use
- Light-weighted design, 30% lighter than the same specification products.
- Wide voltage 10-80V, compatible with a variety of motorcycles, electric vehicle models
- Patented hook handlebar, load-bearing up to 5kg
- Power switch + indicator light: press 1st to start charging, the blue indicator light is on, press 2nd to start cooling and heat dissipation, and then press 3rd to shut down, the indicator light turns off.
- Power input, output, over-current, short circuit, over-temperature, reverse protection, etc.
- Power cord: 1.5 meters with 5A fuse + SAE interface



Charging: Input: DC 10V-80V

Cooling Off, Output: USB A+TYPE-C: 5V 4A (max)

Cooling on, Output: USB A+TYPE-C: 5V 2.5A (max)

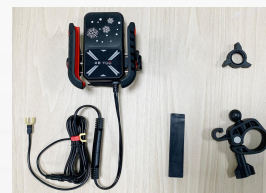

YF-332-A1

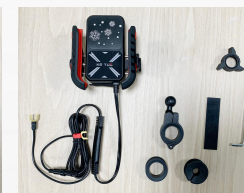

YF-332-A2

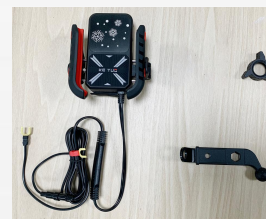

YF-332-B1

1 pcs/gift box

A1 A2 B1

NW: 301g 299g 292g

GW: 381g 379g 372g

Holder Size: 98*110*52 mm

Box Size: 160*120*110mm H

Packing: 50pcs/carton

Carton size: 62*34*57.5cm

Carton GW: 20.5kg

YF-332 Plus

• Patent ID : Pending

Cycling cooling and heat dissipation Mounting

Main material: PA66+30% GF+aluminum alloy
 Cooling plate material: ceramic substrate+bismuth telluride
 Cooling plate size: 23*23*4.2mm
 Cooling power consumption: 5V 1.5A (including fan)
 Installation method: handlebar/rearview mirror
 Pipe diameter: 12-33mm
 Mobile phone width: 66-92mm Length: 120-200mm Maximum thickness: 14mm
 Support: motorcycles, tricycles, electric bicycles, etc.



YF-332-A1 Plus



YF-332-A2 Plus



YF-332-B1 Plus



Detachable

- Flagship refrigeration new product, high conduction + large area refrigeration, cooling temperature down to 5°C, ice-cold in an instant when turned on
- Professional torque adjustment product width, precision threaded steel, shock-resistant and anti-slip, stable protection
- Symmetrical double-sided silicone clamping, uniform force
- Patented design reinforced base, firmly locks the handlebars, and calmly faces a variety of complex road conditions
- IP68 brand cooling fan, low power consumption, 5000RPM, life span 30000 hours
- Whole Device IP66 level
- Storage under room temperature
- The bracket and radiator adopt push design, one push and one loose, can be separated
- 360° selection, mobile phone viewing angle can be adjusted at will
- Professional design, does not block the camera and charging port, mobile phone is more convenient to use
- Light-weighted design, 30% lighter than the same specification products.
- Wide voltage 10-80V, compatible with a variety of motorcycles, electric vehicle models
- Patented hook handlebar, load-bearing up to 5kg
- Power switch + indicator light: press 1st to start charging, the blue indicator light is on, press 2nd to start cooling and heat dissipation, and then press 3rd to shut down, the indicator light turns off.
- Power input, output, over-current, short circuit, over-temperature, reverse protection, etc.
- Power cord: 1.5 meters with 5A fuse + SAE interface



Charging: Input: DC 10V-80V

Cooling Off, Output: USB A+TYPE-C: 5V 4A (max)

Cooling on, Output: USB A+TYPE-C: 5V 2.5A (max)

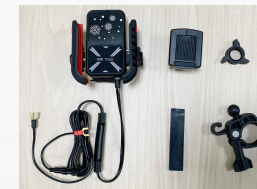

YF-332-A1 Plus

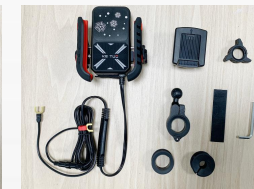

YF-332-A2 Plus



YF-332-B1 Plus

1 pcs/gift box

A1 A2 B1

NW: 331g 329g 322g

GW: 411g 409g 402g

Holder Size: 98*110*52 mm

Box Size: 160*120*110mm H

Packing: 50pcs/carton

Carton size: 62*34*57.5cm

Carton GW: 21.5kg

YF-329-A1

- Utility Model Patent: ZL2024 2 2393785.5
- Design Patent: ZL 2025 3 0375038.6

Quicklock phone holder

Material: PC+ABS+Aluminum/PA6+30GF

Mounting Type: Handlebar

Pipe clamp dia.: 12-33mm

Phone size: Universal

Support: Motorcycle, Tricycle, E-bike, Bicycle



- The phone can be easily taken and placed with one hand
- Built-in magnetic iron ring helps for wireless charging alignment
- One-step press to install in place, the bracket 4 buckles firmly lock the mobile phone sticker
- Quick-release handle + safety switch, stabilize the mobile phone and prevent misoperation
- Hand-feel glass bead positioning, 360° angle adjustment of the mobile phone position
- Patented soft rubber shock absorption, optimized structure, light and effective
- Independent removal of mobile phone case
- Handlebar with hook load-bearing capacity of up to 5kg
- Main body is environmentally friendly PC, high strength and high elasticity, suitable for a wide range of temperatures

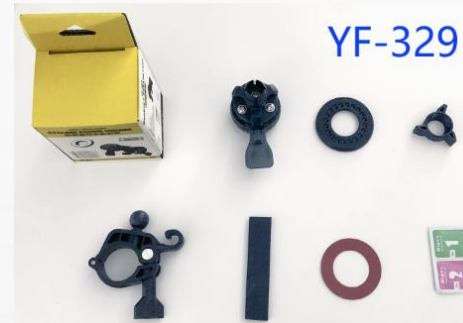

1pcs/gift box
 Net Weight: 182g
 Body Size: $\phi 49 \times 66$ mm
 Panel Size: $\phi 57 \times 5$ mm
 Box Size: 80*65*103mm H

Packing: 100pcs/carton
 Carton size: 66*22*41.5cm
 Carton GW: 19.7kg

Note: Silicone Incompatibility: The double-sided adhesive is not suitable for silicone cases or coatings with finger print-resistant technology. Opt for hard-material cases (stainless steel or PC)

YF-329-A2

- Utility Model Patent: ZL2024 2 2393785.5
- Design Patent: ZL 2025 3 0375038.6

Quicklock phone holder

Material: PC+ABS+Aluminum/PA6+30GF

Mounting Type: Handlebar

Pipe clamp dia.: 12-33mm

Phone size: Universal

Support: Motorcycle, Tricycle, E-bike, Bicycle



- The phone can be easily taken and placed with one hand
- Mobile phone fast charging module, built-in magnetic iron ring assisted alignment mobile phone wireless charging center, automatic adsorption alignment charging
- One-step press to install in place, the bracket 4 buckles firmly lock the mobile phone sticker
- Quick-release handle + safety switch, stabilize the mobile phone and prevent misoperation
- Hand-feel glass bead positioning, 360° angle adjustment of the mobile phone position
- Patented soft rubber shock absorption, optimized structure, light and effective
- Independent removal of mobile phone case
- Main body is environmentally friendly PC, high strength and high elasticity. suitable for a wide range of temperatures



1pcs/gift box
 NW: 141g GW: 175g
 Body Size: $\phi 49 \times 66$ mm
 Panel Size: $\phi 57 \times 5$ mm
 Box Size: 80*65*103mm H

Packing: 100pcs/carton
 Carton size: 66*22*41.5cm
 Carton GW: 18.5kg

Note: Silicone Incompatibility: The double-sided adhesive is not suitable for silicone cases or coatings with finger print-resistant technology. Opt for hard-material cases (stainless steel or PC)

YF-311-A/B

Cycling phone holder

- Utility Model Patent In China: ZL 2025 2 0168745.2
- EU Design: 015095574-0001
- Design Patent in Japanese: 1810296
- Design Patent in Taiwan: D241579

Material: PA66+30%GF+Silicone+Aluminum Alloy

Mounting Type: Handlebar / Mirrorbase

Pipe clamp dia.: 12-33mm Mirrorhole dia: 10mm

Phone Width: 64-90mm Thickness: 12.5mm Length: 120-200mm

Support: Motorcycle, Tricycle, E-bike, Bicycle

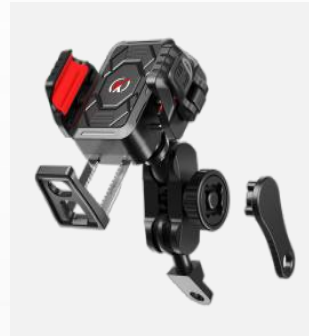
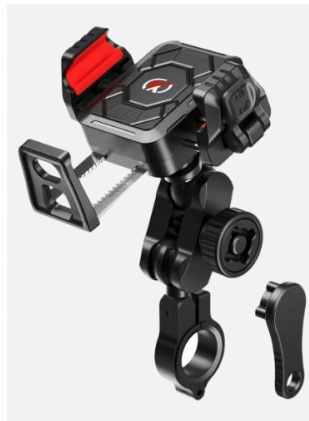

- Elegant patterns, compact design
- Quick lock Installation
- Pull down component with scale and protective lock, mechanical sensing push - pull stroke, sensitive locking position
- GoPro camera bracket extension
- Mini 60mm aluminum alloy clips (regular 80mm)
- Thickened silicone protection
- Anti-dampener



A Handlebar



B Mirrorbase

1pcs/gift box

Net Weight: A1 Handlebar: 401g

B1 Mirrorbase: 361g

Holder Size: 88*75*60mm

Box size: 175*100*92mm

Packing: 50pcs / carton

carton size: 52*37*47.5 cm

Carton GW: A1: 21 kg B1: 19kg

YF-311-A/B Plus

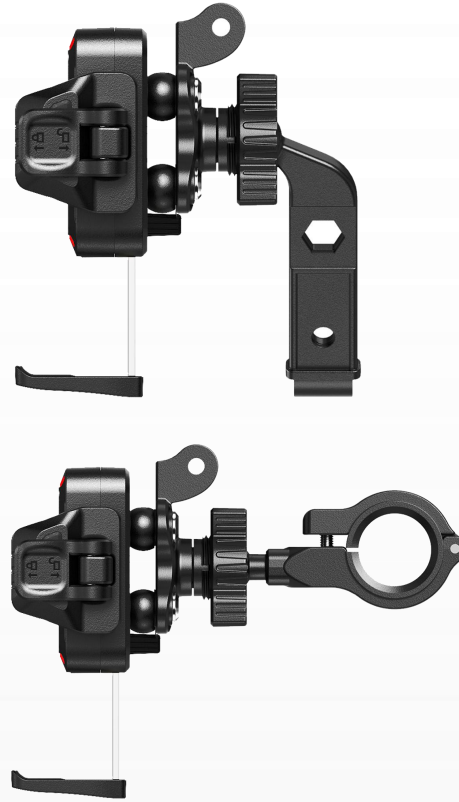

Cycling phone holder

- Utility Model Patent In China: ZL 2025 2 0168745.2
- EU Design: 015095574-0001
- Design Patent in Japanese: 1810296
- Design Patent in Taiwan: D241579

Material: PA66+30%GF+Silicone+Aluminum Alloy

Mounting Type: Handlebar / Mirrorbase

Pipe clamp dia.: 12-33mm Mirrorhole dia: 10mm

Phone Width: 64-90mm Thickness: 12.5mm Length: 120-200mm

Support: Motorcycle, Tricycle, E-bike, Bicycle

- Elegant patterns, compact design
- Quick lock Installation
- Pull down component with scale and protective lock, mechanical sensing push - pull stroke, sensitive locking position
- GoPro camera bracket extension
- Mini 60mm aluminum alloy clips (regular 80mm)
- Thickened silicone protection
- Anti-dampener



A2 Handlebar



B2 Mirrorbase

1pcs/gift box

Net Weight:

A1 Handlebar: 324g

B1 Mirrorbase: 318g

Holder Size: 88*75*60mm

Box size: 175*100*92mm

Packing: 50pcs / carton

carton size: 52*37*47.5 cm

Carton GW: A1 17.5 kg B1: 17kg

YF-311-C/D

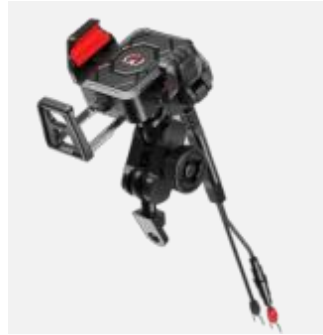

- Elegant patterns, compact design
- Quick lock Installation
- LED charging On-off indicator
- Reverse connection short circuit protection
- Pull down component with scale and protective lock, mechanical sensing push - pull stroke , sensitive locking position
- GoPro camera bracket extension
- IP6X waterproof and dustproof protection
- Mini 60mm aluminum alloy clips (regular 80mm)
- Thickened silicone protection
- Anti-dampener
- 17mm/25mm ball head expansion Mounting Type 1. 4mcable with SAE socket+ 5A fuse

- Utility Model Patent In China: ZL 2025 2 0168745.2
- EU Design: 015095574-0001
- Design Patent in Japanese: 1810296
- Design Patent in Taiwan: D241579

Material: PA66+30%GF+Silicone+Aluminum Alloy

Waterproof: IP67

Mounting Type: Handlebar / Mirrorbase

Pipe clamp dia.: 12-33mm Mirrorhole dia: 10mm

Phone Width: 64-90mm Thickness: 12.5mm Length: 120-200mm

Support: Motorcycle, Tricycle, E-bike, Bicycle

Charging: Input: DC 10V-24V

Output: Wireless: 15W

TYPE-C 33W



C Charging Handlebar



D Charging Mirrorbase

1pcs/gift box

Net Weight: C Handlebar: 472g
D Mirrorbase: 431g

Holder Size: 88*75*60mm

Box size: 175*100*90mm

Packing: 50pcs / carton

carton size: 52*37*47.5 cm

Carton GW: C 24.6 kg D: 22.5 kg

YF-312-A/B

- Patent ZL 2025 3 0050256.2

Cycling phone holder

Material: PA66+30%GF+Silicone+Aluminum Alloy

Mounting Type: Handlebar / Mirrorbase

Pipe clamp dia.: 12-33mm Mirrorhole dia.: 10mm

Phone Width: 64-100mm Thickness: 14mm Length: 120-200mm

Support: Motorcycle, Tricycle, E-bike, Bicycle



- Light-weighted Version
- Smart design, not blocking camera and other mobile interfaces
- Quick Release and Installation
- The base is quick to install on the handlebar
- Weighing hook, load-limit 5kg
- Thicked-silicon pad protection
- 360° rotation



- A Handlebar B Mirrorbase
-
-
-

1pcs/gift box
 Net Weight:
 A Handlebar: 242g
 B Mirrorbase: 187g
 Holder Size: 91*100*49mm
 Box Size: 90*95*115mm
 Packing: 80pcs / carton
 Ctn Size: 48.5*40*48.5 cm
 Carton GW:
 A Handlebar: 20.5 kg
 B Mirrorbase: 16 kg

YF-312-A/B PRO

• Patent ZL 2025 3 0050256.2

Cycling phone holder

Material: PA66+30%GF+Silicone+Aluminum Alloy

Mounting Type: Handlebar / Mirrorbase

Pipe clamp dia.: 12-33mm Mirrorhole dia: 10mm

Phone Width: 64-100mm Thickness: 14mm Length: 120-200mm

Support: Motorcycle, Tricycle, E-bike, Bicycle

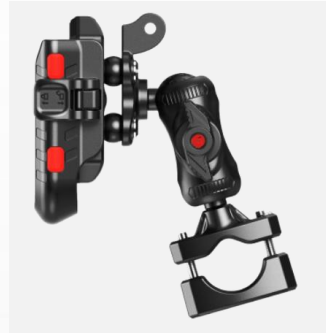

- Light-weighted Version
- Smart design, not blocking camera and other mobile interfaces
- Quick Release and Installation
- The base is quick to install on the handlebar
- Thicked-silicon pad protection
- 360° rotation



A Pro Handlebar



B Pro Mirrorbase

1pcs/gift box

Net Weight:

A Pro Handlebar: 340g

B Pro Mirrorbase: 306g

Holder Size: 91*100*49mm

Box Size: 90*95*115mm

Packing: 80pcs / carton

Ctn Size: 48.5*40*48.5 cm

Ctn GW:

A Pro Handlebar: 28.5 kg

B Pro Mirrorbase: 25 kg

YF-312-A/B PRO

• Patent ZL 2025 3 0050256.2

Cycling phone holder

Material: PA66+30%GF+Silicone+Aluminum Alloy

Mounting Type: Handlebar / Mirrorbase

Pipe clamp dia.: 12-33mm Mirrorhole dia: 10mm

Phone Width: 64-100mm Thickness: 14mm Length: 120-200mm

Support: Motorcycle, Tricycle, E-bike, Bicycle

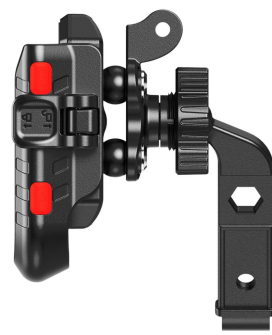
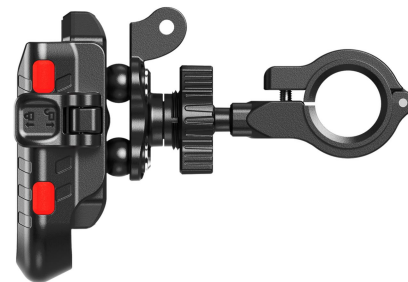

- Light-weighted Version
- Smart design, not blocking camera and other mobile interfaces
- Quick Release and Installation
- The base is quick to install on the handlebar
- Thicked-silicon pad protection
- 360° rotation



A Plus Handlebar



B Plus Mirrorbase

1pcs/gift box
Net Weight:

A Plus Handlebar: 246g

B Plus Mirrorbase: 240g

Holder Size: 91*100*49mm

Box Size: 90*95*115mm

Packing: 80pcs / carton

Carton Size: 48.5*40*48.5 cm

Carton GW:

A Plus Handlebar: 20.5 kg

B Plus Mirrorbase: 20.2 kg

YF-320

- Patent ID: ZL 2025 3 0030064.5

Cycling phone holder

Material: Aluminum Alloy+PP+10%GF+Silicone

Waterproof: IP67

Color: Black / Silver

Mounting Type: Handlebar

Pipe clamp diameter: 22-33mm

Phone Width: 60-100mm Thickness: 20mm max

Support: Motorcycle, Tricycle, E-bike, Bicycle

Charging: Input: DC 10V-80V

Output: USB + TYPE-C 5V 3.2A



1pcs/gift box

Net Weight: 172 g

GW: 194g

Size: 105*85*72 mm

Packing: 100 pcs / carton

Carton size: 44.5*44*38cm

Carton GW: 21 kg



treatment



- Wide voltage input 10V-80V
- Turn on/off the charging power switch
- Retractable cabin design with anti-drop screw
- Reverse protection
- Short circuit protection
- IP56 waterproof and dustproof protection
- Thickened silicone foot cover
- Light-weighted Integrated handlebars and shock-protective
- 1.4m cable with SAE socket + 5A fuse

YF-322-A1

• Patent ID: ZL 2025 3 0030065.X

Quicklock phone holder



Material: PC+Aluminum

Mounting Type: Handlebar

Pipe clamp dia.: 12-33mm

Phone size: Universal

Support: Motorcycle, Tricycle, E-bike, Bicycle

- Quick Release operation
- Premium material
- 360° Rotation
- Weighing hook, load-bearing capacity up to 5kg
- Independent disassembly of phone attachment
- The base is quick to install on the handlebar
- Environmentally friendly PC with high strength and elasticity,
- Suitable for a wide range of temperatures

Note: Silicone Incompatibility: The double-sided adhesive is not suitable for silicone cases or coatings with finger print-resistant technology. Opt for hard-material cases (stainless steel or PC)



1pcs/gift box

Net Weight: 139g

Body Size: 50*60*42mm

Panel Size: 50*60*4mm

Box Size: 70*55*110mm H

Packing: 160 pcs / carton

Carton size: 37*29.5*46 cm

Carton GW: 23.5 kg

YF-322-A2

• Patent ID: ZL 2025 3 0030065.X

Quicklock phone holder

Material: PC+Aluminum

Mounting Type: CNC Handlebar

Pipe clamp dia.: 12-33mm

Mounting Type: CNC Handlebar

Phone size: Universal

Support: Motorcycle, Tricycle, E-bike, Bicycle



- Quick Release operation
- Premium material
- 360° Rotation
- Independent disassembly of phone attachment
- The base is quick to install on the handlebar
- Aviation grade aluminum alloy handlebars are flexible and sturdy
- Environmentally friendly PC with high strength and elasticity, suitable for a wide range of temperatures

Note: Silicone Incompatibility: The double-sided adhesive is not suitable for silicone cases or coatings with finger print-resistant technology. Opt for hard-material cases (stainless steel or PC)



1pcs/gift box

NW: 72g GW: 119g

Body Size: 50*60*36mm

Panel Size: 50*60*4mm

Box Size: 70*55*110mm H

Packing: 160 pcs / carton

Carton size: 37*29.5*46 cm

Carton GW: 20.5 kg

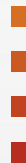

KT-315-A/B

• Patent ID: ZL 2024 3 0758947.3

Cycling phone holder

Material: PA66+30%GF+Silicone

Color: Multi-color, black, black-yellow

Mounting Type: Handlebar/Mirror

Pipe clamp dia.: 19-33mm Mirrorhole dia.: 10mm

Phone Width: 60-86mm Thickness: 22mm Length: 136-190mm

Support: Motorcycle, Tricycle, E-bike, Bicycle



A Handlebar



B Mirrorbase

- Eight Claw Protection
- High toughness material
- Air cushion shock absorption
- One-hand operation
- Flexibly pull up and down
- Thickened silicone foot cover
- Camera Connection Extension

1pcs/gift box

NW: 424g GW: 498g (A Handlebar)

NW: 378g GW: 452g (B Mirrorbase)

Size:175*100*108mm

Packing: 50pcs / carton

Carton size: 54.5*38*57 cm

Carton GW: 26 kg (A handlebar)

23.5kg (B mirrorbase)

KT-315-C/D

• Patent ID: ZL 2024 3 0758947.3

Cycling phone holder

Material: PA66+30%GF+Silicone

Color: Multi-color, black, black-yellow

Mounting Type: Handlebar/Mirror

Pipe clamp dia.: 19-33mm Mirrorhole dia.: 10mm

Phone Width: 60-86mm Thickness: 22mm Length: 136-190mm

Support: Motorcycle, Tricycle, E-bike, Bicycle



- Eight Claw Protection
- High toughness material
- Air cushion shock absorption
- One-hand operation
- Flexibly pull up and down
- Thickened silicone foot cover

Charging: Input: DC 12V-24V

Output: TYPE C 33W Wireless Charging 15W



C Charging Handlebar



D Charging Mirrorbase

1pcs/gift box
 NW: 482g GW: 570g (C Handlebar)
 NW: 442g GW: 540g (D Mirrorbase)

Size: 175*100*108mm

Packing: 50pcs / carton
 Carton size: 54.5*38*57 cm
 Carton GW: 29.5 kg (C handlebar)
 28kg (D mirrorbase)

YF-305-A/B



Cycling phone holder

Material: Alluminum

Mounting Type : Handlebar/Mirror

Pipe clamp dia.: 19-33mm Mirrorhole dia.: 10mm

Phone Width: 64-112mm Length: 120-200mm Thickness: 13mm

Support: Motorcycle, Tricycle, E-bike, Bicycle

- High Quality Alluminum Alloy
- One-hand operation
- Multi-color Available
- Silicone Pad Protection
- Retractable cabin design with anti-drop screw
- Hold mobile phone widths of 64 - 112mm



A Handlebar



B Mirrorbase

1pcs/gift box

NW: 240g GW: 276g (A Handlebar)

NW: 206g GW: 242g (B Mirrorbase)

Size:120*95*60mm

Packing: 50pcs / carton

Carton size: 51*25*34 cm

Carton GW: 14.8 kg (A handlebar)

13 kg (B mirrorbase)

YF-305-C/D



Cycling phone holder

Material: Alluminum
Mounting Type: Handlebar/Mirror

Pipe clamp dia.: 19-33mm Mirrorhole dia.: 10mm

Phone Width: 64-112mm Length: 120-200mm Thickness: 13mm
Support: Motorcycle, Tricycle, E-bike, Bicycle

Charging: Input: DC 12V-24V
Output: USB 18W TYPE-C 33W

- High Quality Alluminum Alloy
- One-hand operation
- Multi-color Available
- Silicon Pad Protection
- Retractable cabin design with anti-drop screw
- Hold mobile phone widths of 64 - 112mm
- Protection design of charging port



C Charging Handlebar



D Charging Mirrorbase

1pcs/gift box
C Handlebar
NW: 325g GW: 361g
D Mirrorbase
NW: 291g GW: 327g
Size:120*95*60mm

Packing: 50pcs / carton
Carton size: 51*25*34 cm
Carton GW: C handlebar:19 kg
D mirrorbase:17.25 kg

YF-308-A/B

• Patent No.: ZL 2024 3 0618477.0



Cycling phone holder

Material: ABS+PC

Suitable for phone size:

YF-308L: 5.5-6.8 inch (168X83X10.5mm (max)) YF-308S:

4.7-5.7 inch (152X76X10.5mm (max))

Mounting Type: Handlebar / Mirror

Pipe clamp dia.: 12-33mm Mirrorhole dia.: 10mm

- Premium interior design to prevent the phone from scratches or abrasions
- Touchable Transparent Screen, and can operate the mobile phone directly
- Silicone mat protection against shocks
- The waterproof case is detachable and can be carried around
- The upper and lower parts of the magnetic buckle double to ensure the stability of the structure
- IP67 waterproof rating, not afraid of heavy rain
- The base is quick and easy to install



A Handlebar B Mirrorbase

1pcs/gift box

Weight: S: 376g L:391g

Size:209*106*90mm

Packing: 60pcs / carton

Carton size: 56*43*57.2 cm

Carton GW: 25 kg

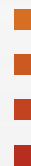

YF-308-C/D

• Patent No.: ZL 2024 3 0618477.0



- Premium interior design to prevent the phone from scratches or abrasions
- Transparent front is touchable, and can operate the mobile phone directly
- Silicone mat protection against shocks
- The waterproof case is detachable and can be carried around
- The upper and lower parts of the magnetic buckle double to ensure the stability of the structure
- IP67 waterproof rating, not afraid of heavy rain
- The base is quick and easy to install
- Wireless fast charging support
- Charging port protection
- Anti-theft installation gadget

Cycling phone holder

Material : ABS+PC
 Waterproof: IP67
 Suitable for phone size :
 YF-308L: 5.5-6.8 inch (168X83X10.5mm (max))
 YF-308S: 4.7-5.7 inch (152X76X10.5mm (max))
 Mounting Type : Handlebar/Mirror
 Pipe clamp dia.: 19-33mm Mirrorhole dia.: 10mm

Charging: Input: DC 12V-24V
 Output: USB 18W TYPE-C 33W Wireless: 15W



C Charging Handlebar



D Charging Mirrorbase

1pcs/gift box
 Weight: S:551g L:566g
 Size: 209*106*90mm

Packing: 50pcs / carton
 Carton size: 55*43*48 cm
 Carton GW: 30kg

YF-303-A/B

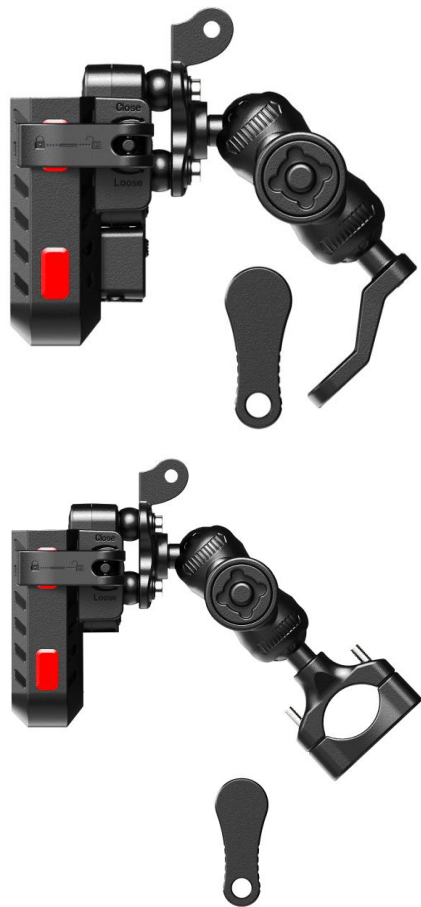

Cycling phone holder

Material: PA66+30%GF

Mounting Type : Handlebar/Mirror

Pipe clamp dia.: 12-33mm Mirrorhole dia.: 10mm

Support: Motorcycle, Tricycle, E-bike, Bicycle

Phone width: 64-90mm length: 120-200mm max thickness: 16mm

- One handed quick put and place operation
- Air bag shock absorption design
- Anti theft design
- One quick lock of phone
- Security phones are suitable
- Support GO-PRO and suncap installation



A Handlebar

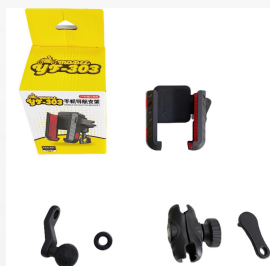

B Mirrorbase

1pcs/gift box

NW: A-300g B- 227g

GW: A-337g B- 263g

Size: 95*100*115mm

Packing: 80pcs / carton

Carton size: 49.5*45.5*38.5cm

Carton GW: A-28.1 kg

B-22.2 kg

YF-303-A/B Plus

Cycling phone holder

Material: PA66+30%GF

Mounting Type : Handlebar/Mirror

Pipe clamp dia.: 12-33mm Mirrorhole dia.: 10mm

Support: Motorcycle, Tricycle, E-bike, Bicycle

phone width: 64-90mm length: 120-200mm max thickness: 16mm



- One handed shortcut operation
- Air bag shock absorption design
- Anti theft design
- One quick lock of phone
- Security phones are suitable
- Support GO-PRO and suncap installation



A



B Plus Mirrorbase

1pcs/gift box

NW: A Plus- 243g B Plus- 230g

GW: A Plus- 280g B Plus- 267g

Size: 95*100*115mm

Packing: 80pcs / carton

Carton size: 49.5*45.5*38.5cm

Carton GW: A Plus- 23.9 kg

B Plus- 22.8 kg



YF-303-C/D



Cycling phone holder

Material: PA66+30%GF

Mounting Type: Handlebar/Mirror

Pipe clamp dia.: 19-33mm Mirrorhole dia.: 10mm

Support: Motorcycle, Tricycle, E-bike, Bicycle

Phone width: 64-90mm length: 120-200mm max thickness: 16mm

Charging: Input: DC 12V-24V

Output: USB 18W TYPE-C 33W

- One handed shortcut operation
- Air bag shock absorption design
- Anti theft design
- One quick lock of phone
- Security phones are suitable
- Support GO-PRO and suncap installation



■ C Charging Handlebar
■ D Charging Mirrorbase

1pcs/gift box
 Weight: 426g
 Size: 95*100*115mm

Packing: 60pcs / carton
 Carton size:
 49.5*45.5*38.5cm
 Carton GW: 27.1kg

YF-301-A/B

• Patent No.: ZL 2024 3 0433208.7

Cycling phone holder

Material: ABS+PC

Pipe clamp dia.: 19-33mm Mirrorhole dia.: 10mm

Mounting Type: Handlebar/Mirror

Phone width: 64-90mm length: 140-190mm max thickness: 22mm

Support: Motorcycle, Tricycle, E-bike, Bicycle



- High toughness material
- Shock absorption with self suspension limit
- One-hand operation
- Cute phone hat can be sold seperately
- Camera bracket support
- Phone-Locking button
- Rainproof and anti-UV



A Handlebar



B Mirrorbase

1pcs/gift box
Weight: 764g
Size:190*151*158mm

Packing: 36pcs / carton
Carton size: 63*60*49cm
Carton GW: A: 28.5kg
B: 27.1kg

YF-301-C/D

• Patent No.: ZL 2024 3 0433208.7

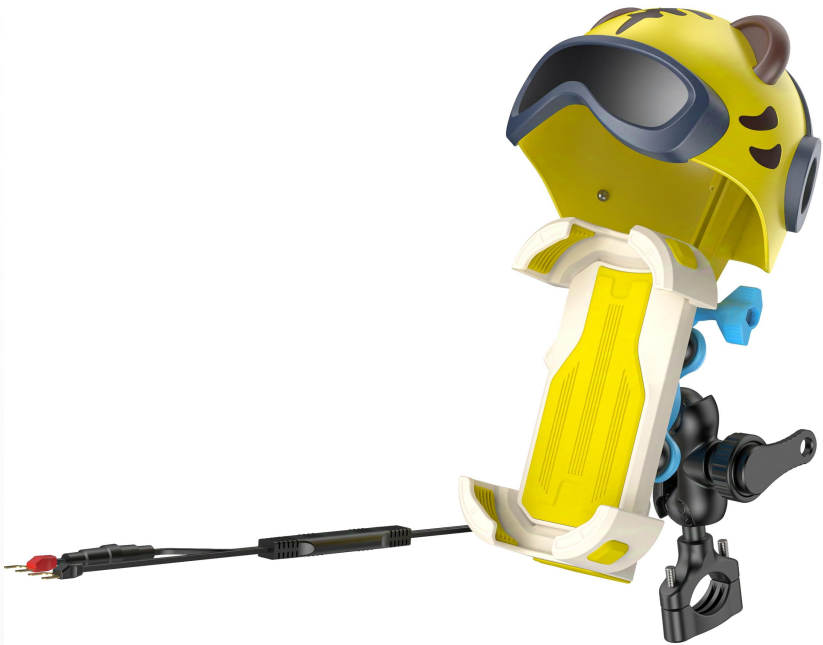

Cycling phone holder

Material: ABS+PC

Mounting Type: Handlebar/Mirror

Pipe clamp dia.: 19-33mm Mirrorhole dia.: 10mm

Phone width: 64-90mm length: 140-190mm max thickness: 22mm

Support: Motorcycle, Tricycle, E-bike, Bicycle

Charging: Input: DC 12V-24V

Output: USB 18W TYPE-C 33W Wireless: 15W

- High toughness material
- Shock absorption with self suspension limit
- Cute phone hat can be sold seperately
- Phone-Locking button
- Camera bracket support
- One-hand operation
- Rainproof and anti-UV



C Charging Handlebar



D Charging Mirrorbase

1pcs/gift box
Weight: 834g
Size: 190*151*158mm

Packing: 36pcs / carton
Carton size: 63*60*49cm
Carton GW: A: 31.5kg
B: 30kg

YF-290-A/B

- Patent ID: ZL 2023 3 0690062.X



Cycling phone holder

Material: PA66+30%GF

Mounting Type: Handlebar/Mirror

Pipe clamp dia.: 19-33mm Mirrorhole dia.: 10mm

Phone width: 64-86mm length: 130-175mm max thickness: 27mm

Support: Motorcycle, Tricycle, E-bike, Bicycle

- High toughness material
- Shock absorption with self suspension limit
- One-hand operation
- Flexibly pull up and down
- Thickened silicone foot cover



A Handlebar

B Mirrorbase

1pcs/gift box
Weight: 477g
Size: 160*100*108mm

Packing: 50pcs / carton
Carton size: 52*34*57cm
Carton GW: 24.9kg

YF-288-A/B

- Design Patent: ZL2023 3 0581599 .2
- Utility model Patent: ZL 2023 2 2451021 .2

Cycling phone holder

Material: PA66+30%GF

Suitable phone width: 63-90mm length: 130-165mm max thickness: 24mm

Mounting Type: Handlebar / Mirror

Pipe clamp dia.: 19-33mm Mirrorhole dia.: 10mm



- High toughness material
- Stainless Steel Adjustable Rod
- One-hand operation
- One key clamp



A Handlebar



B Mirrorbase

1pcs/gift box
 Net Weight: 521g
 Size: 174*170*94mm

Packing: 40 pcs / carton
 Carton size: 72*35*49.5cm
 Carton GW: 22.2kg

YF-288-C/D

Design Patent: ZL2023 3 0581599 .2

Utility model Patent: ZL 2023 2 2451021 .2

Cycling phone holder

Material: PA66+30%GF

Mounting Type: Handlebar / Mirror

Pipe clamp dia.: 19-33mm Mirrorhole dia.: 10mm

Suitable phone width: 63-90mm length: 130-165mm max thickness: 24mm

Charging: Input: DC 12V-24V

Output: USB 18W TYPE-C 33W Wireless: 15W



■ C Charging Handlebar

■ D Charging Mirrorbase

1pcs/gift box
Weight: 664g
Size: 174*170*94mm

Packing: 40 pcs / carton
Carton size: 72*35*49.5cm
Carton GW:27.9kg

- High toughness material
- Stainless Steel Adjustable Rod
- One-hand place and put
- One key clamp



YF-285-A/B

• Design Patent: ZL202430396369.3



Cycling phone holder with camera bracket

Material: PA66+30%GF

Mounting Type: Handlebar / Mirror

Pipe clamp dia.: 19-33mm Mirrorhole dia.: 10mm

Suitable width: 67-90mm

Suitable thickness: 22mm Length: 137-212mm

- Anti-theft
- Shock absorption with self suspension limit
- One-hand operation
- Flexibly pull up and down
- Thickened silicone foot cover
- Sun hat and camera bracket extension



A Handlebar

B Mirrorbase

1pcs/gift box

Weight: 630g

Size:187*113*126mm

Packing: 40 pcs / carton

Ctn size: 60*39.5*52.5cm

Ctn GW: 26.6kg

YF-285-C/D

• Design Patent: ZL202430396369.3

Cycling phone holder with camera bracket

Material: PA66+30%GF

Mounting Type: Handlebar / Mirror

Pipe clamp dia.: 19-33mm Mirrorhole dia.: 10mm

Suitable width: 67-90mm

Suitable thickness: 22mm Length: 137-212mm

Charging: Input: DC 12V-24V

Output: USB 18W TYPE-C 33W Wireless: 15W



- Anti-theft
- Shock absorption with self suspension limit
- One-hand operation
- Flexibly pull up and down
- Thickened silicone foot cover
- Sun hat and camera bracket extension



C Charging Handlebar



D Mirrorbase Charging

1pcs/gift box

Weight: 721.5g

Size: 187*113*126mm

Packing: 40 pcs / carton

Ctn size: 60*39.7*52.5cm

Ctn GW: 31kg

YF-285-A1/B1

- Patent ID: ZL 2024 3 0433207.2

Cycling phone holder with camera bracket

Material: PA66+30%GF

Mounting Type: Handlebar / Mirror

Pipe clamp dia.: 19-33mm Mirrorhole dia.: 10mm

Suitable width: Min67mm-Max90mm

Suitable thickness: 22mm Length: 137-212mm

Support: Motorcycle, Tricycle, E-bike, Bicycle



- Anti-theft
- Shock absorption with self suspension limit
- One-hand operation
- Flexibly pull up and down
- Thickened silicone foot cover
- Sun hat and camera bracket extension



■ A1 Handlebar ■ B1 Mirrorbase

1pcs/gift box
Weight: 590g
Size: 187*113*126mm

Packing: 40pcs / carton
Ctn size: 60*39.7*52.5cm
Carton GW: 25kg

YF-268-C/D

• Patent No.: ZL 202222180035.0

Wireless Charging Mobile Phone Holder

Material: Aluminum Alloy

Color: Black

Mounting Type: Handlebar / Mirror

Pipe clamp dia.:19-33mm Mirrorhole dia.: 10mm

Suitable Phone Width: 67-90mm Thickness: 15mm

Suitable for: Motorcycles

Charging: Input: DC 12V-24V

Wireless charging:15W Type-C: 36W



- CNC High-precision process
- Anodized Aluminum Alloy
- Shock absorption
- One-hand operation
- Protection design of charging port
- Anti-theft design



C Charging Handlebar



D Charging Mirrorbase

1pcs/gift box
Weight: 627g
Size: 156.5*127.5*75.5mm

Packing: 50pcs / carton
Carton size: 67*33*41cm
Carton GW: 31.35kg

YF-258-A/B

• Patent No.: ZL 2022 3 0867444.0

Cycling phone holder

Material: PA66+30%GF

Color: Black

Mounting Type: Handlebar / Mirror

Pipe clamp dia.: 19-33mm Mirrorhole dia.: 10mm

Phone width: 67-90mm Thickness: 22mm Length: 137-212mm

Support: Motorcycle, Tricycle, E-bike, Bicycle



- Shock absorption
- One-hand operation
- Thickened silicone corners
- Compression spring design
- Anti-theft



A Handlebar



B Mirrorbase

1pcs/gift box
Weight: 591g
Size: 187*113*106mm

Packing: 50 pcs / carton
Carton size: 61*40.5*54cm
Carton GW: 31kg

YF-258-C/D

• Patent No.: ZL 2022 3 0867444.0

Cycling phone holder

Material: PA66+30%GF

Color: Black

Mounting Type: Handlebar / Mirror

Pipe clamp dia.:19-33mm Mirrorhole dia.: 10mm

Phone width: 67-90mm Thickness: 22mm Length: 137-212mm

Support: Motorcycle, Tricycle, E-bike, Bicycle

Charging: Input: DC 12V-24V

Wireless charging: 15W



- Shock absorption
- One-hand operation
- Protection design of charging port
- Thickened silicone corners
- Compression spring design
- Sunhat and Go-pro Camera ports



C Charging Handlebar

D Charging Mirrorbase

1pcs/gift box
Weight: 677g
Size: 187*113*106mm

Packing: 40 pcs / carton
Ctn size: 61.5*40.5*43.5cm
Carton GW: 28.4kg

YF-200-A/B

Cycling phone holder

Material: Aluminum Alloy + ABS+Silicon
 Color: Black
 Mounting Type: Handlebar / Mirror
 Pipe clamp dia.: 19-33mm Mirrorhole dia.: 10mm



1pcs/gift box
 Weight: 410g
 Size: 14*7*19.5mm

Packing: 50 pcs / carton
 Carton size: 51*34.5*46.5cm
 Carton GW: 21.5kg

- Shock absorption
- One-hand operation
- Compression spring design



YF-193-A/B

Cycling phone holder

Material: ABS

Color: Black

Mounting Type: Handlebar / Mirror

Pipe clamp dia.: 19-33mm Mirrorhole dia.: 10mm



- Shock absorption
- One-hand operation
- Compression spring design



1pcs/gift box
 Weight: 343.06g
 Size: 180*145*95mm

Packing: 45 pcs / carton
 Carton size: 56.2*46.1*45cm
 Carton GW: 16.7KG



YF-191-A/B

Patent: ZL 2020 3 0696974.4

Cycling phone holder

Material: Alluminum Alloy

Color: Black

Mounting Type: Handlebar / Mirror

Pipe clamp dia.: 19-33mm Mirrorhole dia.: 10mm



- Shock absorption
- One-hand operation
- Compression spring design
- 360°Rotating



A Handlebar

B Mirrorbase

1pcs/gift box
Weight: 572.65g
Size: 220*157*50mm

Packing: 40 pcs / carton
Ctn size: 54*48*33.5cm
Ctn GW: 21.2kg



YF-190-A/B

• Patent: ZL 2020 3 0697267.7

Cycling phone holder

Material: Alluminum Alloy+ABS+silicone

Color: Black

Mounting Type: Handlebar / Mirror

Pipe clamp dia.: 19-33mm Mirrorhole dia.: 10mm

Mirrorbase Hold Dia: 10mm

Suitable phone size: 5-7"

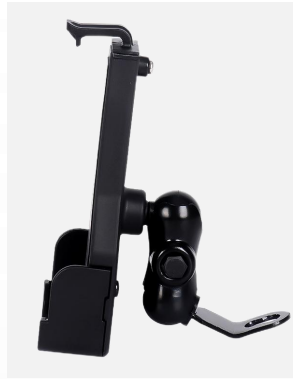

- Triangle Shape, steady
- Silicone Shock absorption One-hand operation
- Compression spring design
- 360° Rotating



1pcs/gift box
Weight: 417.6g
Size: 51*92*149mm

Single Box: 17*17*7.2 cm
Packing: 48 pcs / carton
Carton size: 45.8*36.5*70cm
Carton GW: 21.2kg

YF-188-C/D

• Patent ID: ZL 2021 3 0358859.0



Cycling phone holder

Material: PA66+30%GF

Color: Black

Mounting Type: Handlebar / Mirror

Pipe clamp dia.: 19-33mm Mirrorhole dia.: 10mm

Input: DC10V-24V

Output: USB A: 18W Wireless charging: 15W

- Shock absorption
- One-hand operation
- Compression spring design
- 360°Rotating

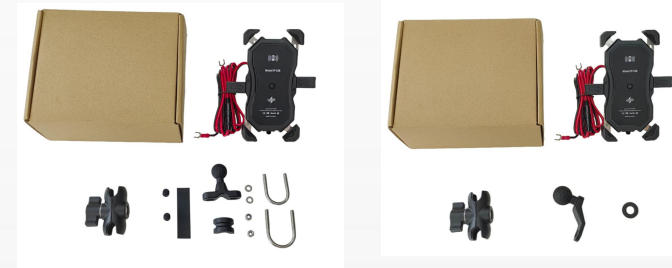

- C Charging Handlebar
- D Charging Mirrorbase

1pcs/gift box
Weight: 495g
Size: 180*145*95mm

Packing: 45 pcs / carton
Ctn size: 56.2*46.1*45cm
Ctn GW: 23.5kg

YF-182

• Patent ID: ZL 2020 3 0407379.4

Multi-function 5V 2A motorcycle phone charger kit

Material: Alu. Alloy + ABS

Color: Black

Phone Size: 4 - 7 inch Width: 79-108mm Height: 132- 180mm

Installation: Handlebar / Mirrorbase

Pipe clamp dia.: 19-33mm Mirrorhole dia.: 10mm

Input: DC10V-24V

Output: USB 5V 2.1A



- Eight claws to install the phone firmly
- Sturdy aluminium body
- Compression spring design
- 360°rotation
- Cable length 1.4 metres

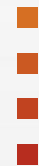

1pcs/gift box
Weight: 460g
Size: 133*90*179mm
Gift box: 165*100*90mm

Single Packing: 165*100*90mm
Packing: 50 pcs / carton
Ctn size: 65.1*34.5*46.5cm
Carton GW: 24.5kg

YF-171-C/D

- Patent ID: ZL 2018.3.0058509.0

X Grip Cycling phone holder

Material: Stainless Steel +PA66+30%GF

Color: Black

Suitable Phone Size: 3.5 - 6 inch

Pipe clamp dia.: 19-33mm Mirrorhole dia.: 10mm

Mounting Type: Handlebar / Mirror

Input: DC10V-24V

Output: USB: 5V 2.1A (3.1Amax)



- X Grip Shock absorption
- One-hand operation
- Compression spring design
- Cable Length: 1.4m

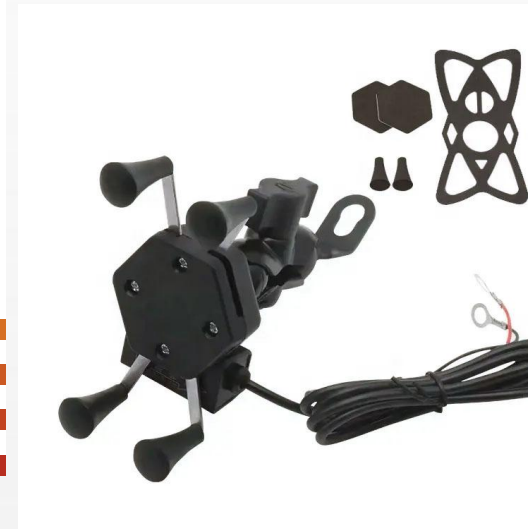

1pcs/gift box
Weight: 280g
Size: 132*70*150mm

Single Packing: 140*95*80mm
Packing: 50 pcs / carton
Carton size: 645*320*360mm
Carton GW: 29kg

Note: The difference between YF-171C and YF-133C is the length of Holder. YF-171C is 16mm longer and can hold bigger size of devices.

YF-143-A/B

Cycling phone holder

Material: Stainless Steel +PA66+30%GF

Color: Black

Suitable Phone Size: 3.5 - 6 inch

Mounting Type: Handlebar / Mirror

Pipe clamp dia.: 19-33mm Mirrorhole dia.: 10mm



1pcs/gift box
Weight: g
Size: 115*70*150mm

Packing: 100 pcs / carton
Carton size: 580*315*500mm
Carton GW: 24.3kg

- Shock absorption
- One-hand operation
- Compression spring design



YF-133-C/D

• Patent ID: ZL 2018.3.0058510.3

X Grip Cycling phone holder

Material: Stainless Steel +PA66+30%GF

Color: Black

Suitable Phone Size: 3.5 - 6 inch

Mounting Type: Handlebar / Mirror

Pipe clamp dia.: 19-33mm Mirrorhole dia.: 10mm

Input: DC10V-24V

Output: USB: 5V 2.1A (3.1Amax)

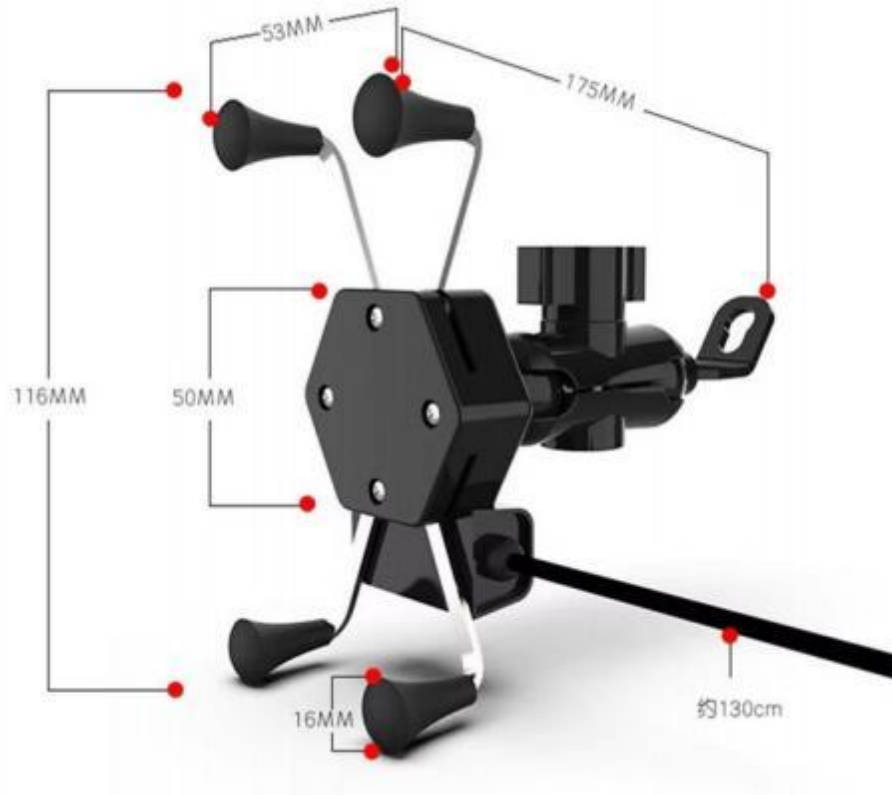

- X Grip Shock absorption
- One-hand operation
- Compression spring design
- Cable Length: 1.4m



1pcs/gift box
Weight: 278g
Size: 116*70*150mm

Single Packing: 130*95*80mm
Packing: 100 pcs / carton
Ctn size: 59*28*50 CM
Carton GW: 29kg

YF-265/266

• Patent No.: ZL 2023 3 0074409.8



YF-265 screen display



YF-266 screen display



- Three colours available
- Fast charging
- convenient use

Universal quick charger

Material: PC+ABS

Color: Pink, White or green

Interface: Wireless charging or USB

Input: 5V/3A 9V/2A

Output: 5V/3A, 5W 9V/2A, 15W



1pcs/gift box
Weight: 228g
Size: 95*90*145mm

Packing: 80pcs / carton
Carton size: 49.5*37.5*59.5cm
Carton GW: 18.2kg



Cycling Charger

Note for the Letters in Model No. :

A: USB A + USB A

B: USB A + Type C

YF-350

2-in-1 Cycling Charger with Extension Cable



Material: ABS

Color: Black

Installation: Handlebar / Mirrorbase

Handlebar Clamp Size: 20-23mm Mirrorbase Hole Dia: 10mm

Charging Ports: TYPE C (40cm extension cable) + USB A

Support: motorcycle, tricycle, electric bicycle

• Input: DC10-80V Output: TYPE C+USB: 5V/3A

- Dual-port (Type C + USB A) fast charging
- Fast charging chip + intelligent power protection
- USB A port emits blue light when powered on
- Power switch
- Dustproof and rainproof cover
- Power cable, 140cm + 5A fuse
- C-type contraction line, 40cm in length
- Supports rearview mirror adapter



1pcs/ craft carton
Craft Box size: 70*54*109mm

Packing: 100pcs / carton
Carton size: 58*23.5*37 cm
Carton GW: kg

YF-331-1

• Patent ID: ZL 2025 3 0386703.1

Quick Charging 3-in-1 Cycling Charger with Retractable Cable

Main material: ABS Color: black
 Installation method: handlebar/mirrorbase
 Handlebar Pipe Dia.: 22-33mm Mirrorbase Dia.: 10mm
 Charging interface: USB A + TYPE C + TYPE C
 QC compatible protocols: FCP, AFC, QC2.0, QC3.0, PD3.0, PPS, etc.
 Support: motorcycle, tricycle, electric bicycle



Handlebar



Mirror base



Running light display instructions:

1. When Power is on, the lights run around once,
2. During charging, the lights keeps running,
3. When the charging stops, and the lights turn out

- Input: DC10-24V
- Output: A 18W: 5V/3A 9V/2A 12V/1.5A
 C 30W: 5V/3A 9V/3A 12V/2.5A
 Retractable Type C 30W: 5V/3A 9V/3A 12V/2.5A



- Voltage indicator
- Charging colorful marquee displays status
- Quick charging chip + intelligent power protection
- 3 ways of independant outputs and fast charging
- Power switch
- Dust and rain cover
- Wire length 140cm with SAE + 5A fuse
- Retractable wire length 70cm



1pcs/ bag
 NW: 177g GW: 210g
 Body Size: 87*49*30mm
 Craft Box size: 130*95*55mm

Packing: 100pcs / carton
 Carton size: 59*28*50 cm
 Carton GW: 24.5kg

YF-331-2

• Patent ID: ZL 2025 3038 6703.1

Quick Charging 3-in-1 Cycling Charger with Retractable Cable

Main material: ABS

Color: black

Installation method: handlebar/mirrorbase

Handlebar Pipe Dia.: 22-33mm

Mirrorbase Dia.: 10mm

Charging interface: USB A + TYPE C + TYPE C

Support: motorcycle, tricycle, electric bicycle



Handlebar



Mirror base



- Voltage indicator
- Charging colorful marquee displays status
- Quick charging chip + intelligent power protection
- Power switch
- Dust and rain cover
- Wire length 140cm with SAE + 5A fuse
- Retractable wire length 70cm

- Input: DC10-80V
- Output: 5V 3A



1pcs/ bag
 NW: 177g GW: 210g
 Body Size: 87*49*30mm
 Craft Box size: 130*95*55mm

Packing: 100pcs / carton
 Carton size: 59*28*50 cm
 Carton GW: 24.5kg

YF-328

• Patent ID: ZL 2025 3 0199445.6



QC3.0 Wall-mounting USB Charger Socket

Material: ABS+Copper
Color: Black

Fast Charging: YES

Support: Smart Phones, iPADS, GPS devices on Any 12V-24V vehicles like Buses, Boats, Motorcycle, ATV, E-bike



- Hidden screw installation design
- With Voltage Indicator (9-29V)
- Fast charging chip (3 Ports Fast Charging Simultaneously)
- Multi-protection + Reverse Protection
- On-off Power
- Dustproof Rainproof Cover
- 14 cm Extension Cables

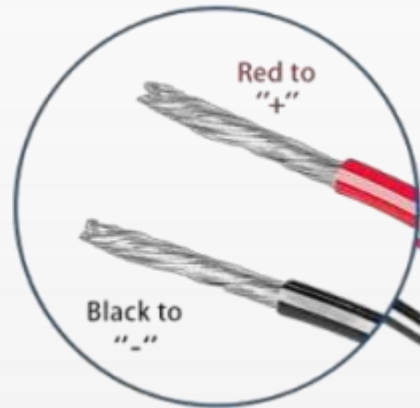

- Input: DC12-24V
- Output: USB A*2: 18W*2 (Max)
TYPE C: 36W (Max)



Screw Length: 2.5cm each

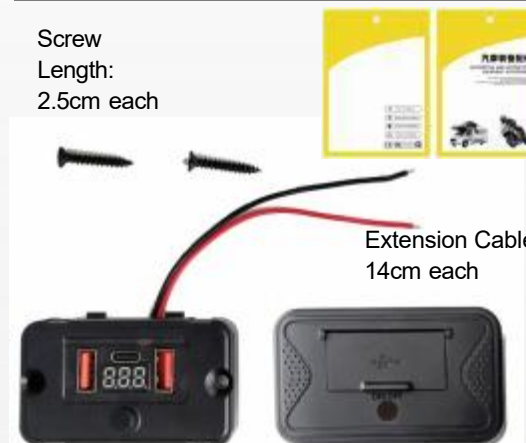

1pcs/Self-sealed OPP bag
Net Weight: 52g
Body Size: 44*72*16mm

Packing: pcs / carton
Carton size: cm
Carton GW: kg

YF-325

Economic Cycling charger with Cigarette Lighter



A: Dual USB A



B: USB A + C



Back View

- IP44 waterproof
- With Cigarette Lighter
- With Voltage Indicator
- Fast charging chip +Smart Protection
- On-off Power
- Dustproof Rainproof Cover
- 140mm cable with 20A fuse

Material: ABS Color: Black
 Fast Charging: YES
 Mounting Type: Handlebar / Mirror
 Handlebar Pipe Dia.: 22-33mm Mirrorbase Dia.: 10mm
 Support: Motorcycle, Tricycle, E-bike

| | | |
|--------------------|--|--------------|
| 1. Input: DC10-80V | Output: A+C/A+A: 5V/3A | No Voltmeter |
| 2. Input: DC10-24V | Output: A: 5V/3A 9V/2A 12V/1.5A C: 5V/3A 9V/3A 12V/1.5A | |
| 3. Input: DC10-24V | Output: A: 5V/3A 9V/2A 12V/1.5A C: 5V/3A 9V/3A 12V/1.5A | No Voltmeter |
| 4. Input: DC10-24V | Output: A+A: 5V/3A | |
| 5. Input: DC10-24V | Output: A+A: 5V/3A | No Voltmeter |



1pcs/craft box
 Net Weight: 177g GW: 210g
 Body Size: 80*65*40mm
 Box size: 130*96*55mm

Packing: 100 pcs / carton
 Carton size: 59*28*50CM
 Carton GW: 21.7kg

YF-323

• Patent ID: ZL 2025 3 0030067.9

Economic Cycling charger

Material: ABS

Color: Black

Fast Charging: YES

Mounting Type: Handlebar / Mirror

Handlebar Pipe Dia.: 22-33mm Mirrorbase Dia.: 10mm

Support: Motorcycle, Tricycle, E-bike



A : Dual USB A



B : USB A + C

Input: DC10-80V
Input: DC10-24V

Output: A+C/A+A: 5V/3A
Output: A: 5V/3A 9V/2A 12V/1.5A
Output: C: 5V/3A 9V/3A 12V/1.5A

No Voltmeter

Input: DC10-24V

Output: A: 5V/3A 9V/2A 12V/1.5A
Output: C: 5V/3A 9V/3A 12V/1.5A

No Voltmeter

Input: DC10-24V
Input: DC10-24V

Output: A+A: 5V/3A
Output: A+A: 5V/3A

No Voltmeter

- IP44 waterproof
- Easy to install
- With Voltage Indicator
- Fast charging chip +Smart Protection
- On-off Power
- Dustproof Rainproof Cover
- 1.4m cable with SAE socket + 5A fuse



USB A + C

USB A + A

1pcs/gift box
Net Weight: 135g
Body Size: 39*26*66mm
Box Size: 70*55*110mm H

Packing: 160 pcs / carton
carton size: 46*37*46cm
Carton GW: 22.6kg

YF-298

• Patent ID: ZL 2025 3 0080159.8



Cycling charger

Material: ABS

Color: Black

Mounting Type: Handlebar / Mirror

Fast Charging: YES

Support: Motorcycle, Tricycle, E-bike

Input: DC10-24V

Output: USB: 5V/3A 9V/2A 12V/1.5A

TYPE-C: 5V/3.5A 9V/3A 12V/3A

- IP44 waterproof
- Easy to install
- With Voltage Indicator
- Fast charging chip
- Voltmeter
- Light on while pressing on the power

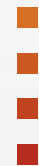

1 pcs/gift box

Gross Weight: 134g

Box Size: 80*80*115mm

Packing: 100 pcs / carton

Carton size: 42.5*36.5*35cm

Carton GW: 14kg

YF-286

• Patent No.: ZL 2024 3 0104365.3

Three-in-one cycling charger

Material: PP+15%GF Color: Black

Mounting Type: Handlebar | Mirrorbase

Handlebar Pipe Dia.: 22-33mm Mirrorbase Dia.: 10mm
 Fast Charging: YES Voltmeter: YES Cigarette Lighter: YES
 Support: Motorcycle, Tricycle, E-bike

- Input: DC10-24V
- Output: USB: 5V/3A, 9V/2A, 12V/1.5A
 TYPE-C: 5V/3.5A, 9V/3A, 12V/3A



- Charging port waterproof
- Cigarette lighter
- Voltage display
- Fast charging chip



1 pcs/gift box
 Weight: 255g
 Size: 85*80*110mm

Packing: 80 pcs / carton
 Carton size: 46.3*43.5*36cm
 Carton GW: 21kg

YF-223



A: Dual USB



B: USB A + C

Dual ports Cycling charger

Material: PP+15%GF

Color: Black

Mounting Type: Handlebar/Mirror

Voltmeter: YES

Fast Charging: YES

Support: Motorcycle, Tricycle, E-bike

- Input: DC10-24V
- Output: USB: **5V-3.4A 9V-2.A 12V-1.5A**
TYPE-C: **5V/3.5A 9V/3A 12V/3A**

- Charging port waterproof
- Temperature & voltage display
- Fast charging chip



1 pcs/gift box
Weight:124g
Size: 80*65*102mm

Packing: 100 pcs / carton
Carton size: 66.5*22*41.5cm
Carton GW: 13.4kg

YF-185

Dual-Port Fast Charging USB Charger with Cable

Main material: ABS + silicone
 Interface: Model A: Dual USB A Model B: USB A + TYPE C
 Color: Black
 Installation method: handlebar
 Supported vehicle types: motorcycles, tricycles, electric vehicles
 Application: mobile phones, tablets, recorders, navigation devices, etc

- Input: DC10-24V
- 1. Model A: Output USB A*2: 18W*2 Max
- 2. Model B: Output USB-A: 18W Max, Type-C: 30W Max

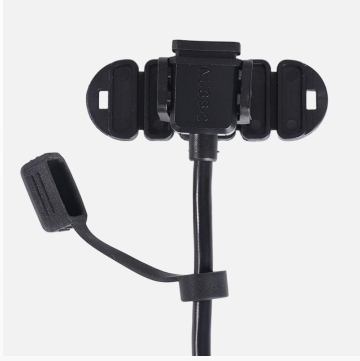

- Waterproof protection for charging interface
- Two independent fast charging paths
- Intelligent Protection
- Auto standby
- Dual USB charging
- 2.5-meter line (2.12-meter main line + extension line: 0.35m)
- SAE interface + 10A fuse



1pcs/color box
 NW of the product:
 Color box size: 15.2 * 4.4 * 22.5CM
 Packaging: 60 pcs/box
 Carton Size: 69 * 47 * 31.5 CM
 Carton GW: 23kg

YF-179

- Design Patent ID: ZL 2020 3 0233761.8



Dual Ports Cycling charger

Material: ABS+Silicone
 Color: Black
 Mounting Type: Handlebar | Mirrorbase
 Cigarette lighter: YES
 Voltmeter: YES
 Support: Motorcycle, Tricycle, E-bike

Input: DC10-24V
 Output: USB: **5V-3.4A**

- Charging port waterproof
- Voltage display
- Dust cover
- On-off switch
- Cigarette Lighter



1 pcs/craft box
 Weight: 201g
 Size: 130*95*55mm

Packing: 100 pcs / carton
 Carton size: 59*28*50CM
 Carton GW: 21kg

YF-178

- Design Patent ID: ZL 2020 3 0407379.4

Dual Ports Cycling charger

Material: ABS+Silicone

Color: Black

Mounting Type: Handlebar | Mirrorbase

Support: Motorcycle, Tricycle, E-bike



- Charging port waterproof
- Dual USB support
- Voltage display
- Dust cover
- On-off switch

Input: DC10-24V

Output: USB: **5V-3.4A**

1 pcs/gift box

Weight: 107g

Size: 70*56*96mm

Packing: 100 pcs / carton

Carton size: 40*36.5*30cm

Carton GW: 11.5kg

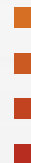

YF-142

Dual Ports Cycling charger

Material: ABS+Silicone

Color: Black

Mounting Type: Handlebar | Mirrorbase

Support: Motorcycle, Tricycle, E-bike



-
- 1. Input: DC10-85V Output: USB*2 : 5V-2.1A Cable: 0.6m
 - 2. Input: DC10-24V Output: USB*2 : 5V-2.1A Cable: 1.4m
-

- Wide Voltage Support
- Charging port waterproof protection
- Dual USB support
- Dust cover
- On-off switch
- Multiple Power Protection

1pcs/gift box
 Weight: g
 Size: 115*70*150mm

Packing: 200 pcs / carton
 Carton size: 71.5*32.5*29CM
 Carton GW: kg



YF-138

• Patent ID: ZL 2017 2 1551390.7

Dual USB Fast Charger with Cigarette Lighter

Material: ABS+Silicone
 Color: Black
 Installation: Handlebar / Mirrorbase
 Support: Motorcycle, Tricycle, E-bike



- 4.2A super large current output
- Waterproof and dustproof cover
- Built-in voltmeter for convenient checking of battery, voltage status at any time,
- 150cm power cable with 20A fuse
- Independent switch for the product, saving electricity
- Cigarette lighter with internal ceramic heat insulation material

- Input: DC10--24V
 Output: USB*2 : 5V--4.2A Cable: 1.5m+20A fuse



1 pcs/gift box
 Weight: 189g
 Size: 83*59*59mm

Packing: 30 pcs / carton
 Carton size: 38.5*23.5*27.3CM
 Carton GW: 12.2kg

03

Phone Holder for Cars

YF-346-198

Vacuum magnetic 3-axis swivel phone stand

Material: Zink Alloy+ABS+TPU

Color: YF-346-198Silver/YF-346-198Grey

Suction Force: 18kpa-65kpa

Suitable Cars: Universal

Suitable Phones: Universal (Magnetic Attraction plates for some phones)

Product size: Magnetic suction diameter 60mm, base diameter 60mm height 177mm



- Mechanical lever-linked alloyarm securely holds your phone.
- Vacuumadsorption tray,Press, lock, and suck
- High-load damping shaft, Precise hovering points
- Infinite joint adjustment 360° arbitrary rotation
- Double wide magnet N54,Strong magnetism/no drift
- Unlimited to cars and phones
- Multiple application; Repeatedly use

Note: The iPhone 12/13/14/15 can be directly attached without the need for magnetic suction. For phones without magnetic suction functionality, the included magnetic plate must be used.

PARTS LIST



1pcs/box with hook
Product NW: 197g
Product GW: 223g
Main Body size: 60*60*177 mm
Box size: 85*50*184 mm

Packing: 100 pcs/ctn
Ctn size: 55*38*45cm
Ctn GW: 27.00kg

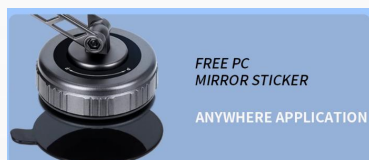

YF-345-188

Vacuum magnetic 3-axis swivel phone stand

Material: Zink Alloy+ABS+TPU

Color: YF-345-188Silver/YF-345-188Grey

Sunction Force: 18kpa-65kpa

Suitable Cars: Universal

Suitable Phones: Universal (Magnetic Attraction plates for some phones)

Product size: Magnetic suction diameter 60mm, base diameter 60mm height 155mm

- Mechanical lever-linked alloyarm securely holds your phone.
- Vacuumadsorption tray,Press, lock, and suck
- High-load damping shaft, Precise hovering points
- Infinite joint adjustment 360° arbitrary rotation
- Double wide magnet N54,Strong magnetism/no drift
- Unlimited to cars and phones
- Multiple application; Repeatedly use

Note: The iPhone 12/13/14/15 can be directly attached without the need for magnetic suction. For phones without magnetic suction functionality, the included magnetic plate must be used.

PARTS LIST



1pcs/box with hook
 Product NW: 200g
 Product GW: 263g
 Main Body size: 60*60*142 mm
 Box size: 90*45*156 mm

Packing: 100 pcs/ctn
 Ctn size: 51.5*32.5*48cm
 Ctn GW: 21.00kg

04

Helmet Bluetooth Headphone

KT-35



Driving recorder+helmet Bluetooth earphones

1. Bluetooth 5.3
2. Built in polymer lithium battery 3.7V
3. Transmission distance: 10M
4. Battery: 1500mAh lithium battery
5. Standby time: 500H, call time: 50H, recorder: 6.5H
6. Support AI voice
7. Pixel count: 2 million, recording method: loop recording
8. Resolution: 1080P
9. Wide angle: 120 °
10. WIFI data transmission: App name: Recorder. English: viidure (Supports Android and iOS)
11. Comes with a 32GB high-speed Micro SD card (supporting ≤ 256GB)
12. Rotate 360 degrees without any dead corners
13. Waterproof rating: IPX6
14. Split installation (dual back clip and main unit can be separated)
15. Support connecting two phones simultaneously
16. Automatic answering of incoming calls (switchable manual mode)



1080P



32G TF card

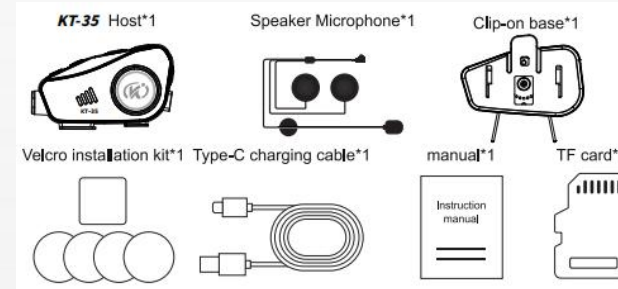

1pcs/gift box
 NW:314g
 Product size: 93*53*25mm
 Box Size: mm
 Packing: pcs / carton
 Carton size: cm
 Carton GW: kg

K30



Helmet Bluetooth Headphone

Mounting position: helmet external

Installation: Clip

Product material: ABS + silicone

Input method: Bluetooth

Bluetooth version: Bluetooth 5.4

Function: voice assistant, plug and play, call answering, end code replay

Application: Apple, Android and other system mobile phones, compatible with iPad, notebook, etc.

Speaker: 40mm 0.5W

Input voltage: 5V

Power supply: built-in lithium battery 3.7V/500mA

Duration: 16H

Standby time: 240 h

Charging time < 2.5H

- Bluetooth 5.4
- Standby 240 hours
- HD sound quality
- Intelligent noise refine
- AI voice assistant
- Support a variety of models
- Auto-answer
- IPX6 waterproof



1pcs/gift box

NW: 47g GW: 128g

Product size: 90*35*17mm

Box Size: 130*100*40mm

Packing: 80 pcs / carton

Carton size: 41*41*30cm

Carton GW: 13kg



05

Camera Holder

YF-280

Camera Holder

Material: PA66+Aluminum clip+Metal ball head

Color: Black

Installation: Handlebar

Clamping Distance: 1.4-4.5cm (0.55-1.77in)

Support: Motorcycle, Tricycle, E-bike, Bicycle



- CNC engraving process
- Quick Release Structure
- Multi-angle adjustment
- Flexible Installation

Note: with different mounting devices, YF-280 can be installed in different places



1pcs/gift box

Weight: 418.5g

Size: 29.5*12.5*4.8cm

Packing: 50 pcs / carton

Carton size: 52.5*35.5*63.5cm

Carton GW: 21.6kg



06

Bottle Holder

YF-297

• Patent ID: ZL 2024 3 0396447.X

Bottle Holder

Material: PA66+30%GF

Color: Black

Installation: Handlebar

Pipe clamp dia.: 19-33mm

The width of kettle can be clipped: 50-90mm

Support: Motorcycle, Tricycle, E-bike, Bicycle



- Shock absorption
- Sturdy, no wobbling
- Light colour changeable
- Adjustable size

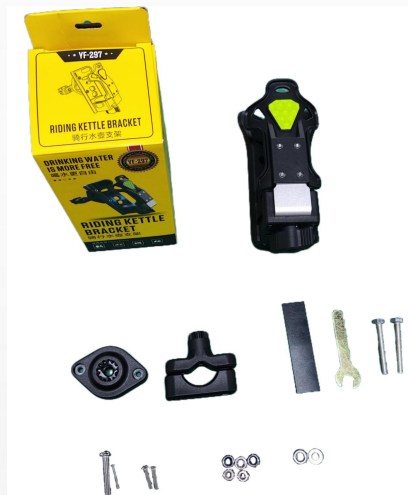

Packing: 1pcs/box
 NW: 383g GW: 423g
 Holder Size: 75*75*14cm
 Box Size: 83*83*17cm

Carton size: 60pcs / carton
 Size: 53*35.5*45cm
 Carton GW: 26.5kg

07

Accessories

YF-333

Helmet Sunhat

Material: PP

Color: White/Black/Pink/Customization

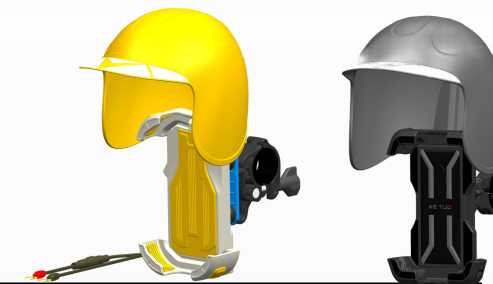
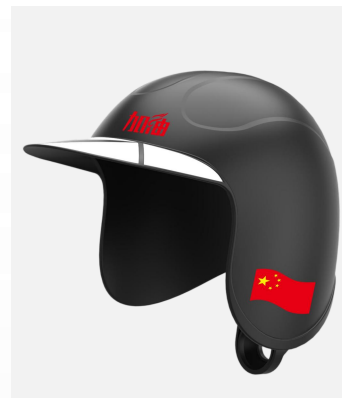

- Multiple Application
- Waterproof
- Angle Adjustment
- Sturdy and durable
- Premium quality material
- DIY available



1pcs/gift box
 Max size:
 135x188x139mm
 NW: 110g GW: 192g
 Box size:
 180x140x150mm

Packing: pcs / carton
 Carton size: cm
 Carton GW: kg

YF-300

- Patent ID: ZL 2024 3 0433208.7

Black Warrior Sun Hat

Material: PA66+30%GF+PC

Color: Black

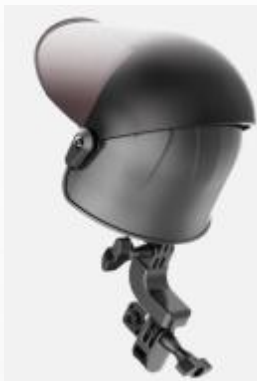

- Waterproof
- Angle Adjustment
- Sturdy and durable
- Premium quality material



1pcs/gift box
 Main body: 140*140*148mm
 Box size: 195*142*95mm
 NW: 249g GW: 341g

Packing: 60 pcs / carton
 Carton size: 72.5*41.5*59cm
 Carton GW: 22.5kg



YF-302

• Patent ID: ZL 2024 3 0433207.2

Cute Tiger Sun Hat

Material: PA66+30%GF

Color: Yellow + Black



- Waterproof
- Angle Adjustment
- Sturdy and durable
- Premium quality material



1pcs/gift box
 NW: 268g GW: 364g
 Box Size: 160*140*115mm

Packing: 60 pcs / carton
 Carton size: 59*66*44.5cm
 Carton GW:23.5kg



Accessory Introduction: Sunhat

YF-M001



Universal Waterproof Dustfree Sunhat

Material: PA66+ABS
Color: Black

Net Weight: 37g
Size: mm
Packing: 1pcs/opp bag

Fittings diagram:



Accessory Introduction: Powerclip

YF-D001

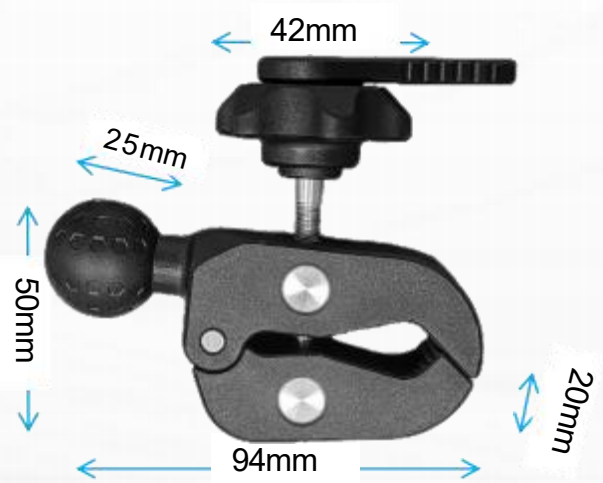

Anti-slippery Pattern



Gold Plated Copper Screw Anti-theft Design

25mm Ball Powerclip

Material: PA66 + Stainless Steel + TPU

Color: Black

Opening Distance: 1.4-4.5cm (0.55-1.77in)

Net Weight: 114g

Size:

Packing: 1pcs/opp bag

Fittings diagram:

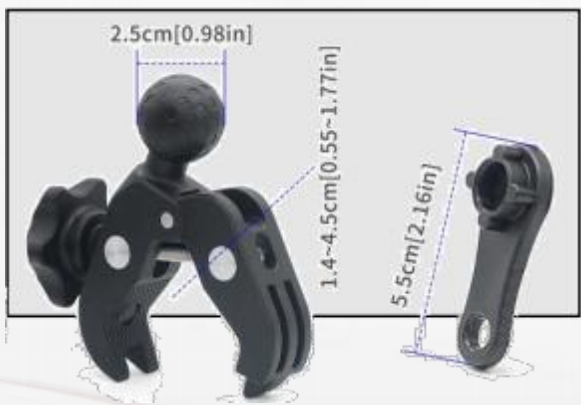

Accessory Introduction: Aluminum CNC handlebar

YF-D002-01



17mm Ball CNC handlebar

Material: Aluminum Alloy
 Color: Black
 Finishing: Oxidation Bright Black
 Pipe Dia: 1.2-3.3cm

Net Weight: 58g
 Body Size: 80*34*15mm
 Packing: 1pcs/opp bag

Fittings diagram:



YF-D002-02



25mm Ball CNC handlebar

Material: Aluminum Alloy
 Color: Black
 Finishing: Oxidation Bright Black
 Pipe Dia: 1.2-3.3cm

Net Weight: 68g
 Body Size: 86*34*15mm
 Packing: 1pcs/opp bag

Fittings diagram:

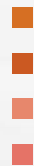
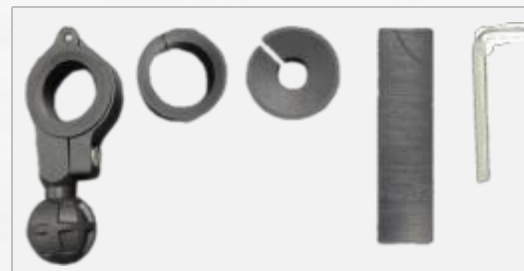

Accessory Introduction: PA66 CNC handlebar

YF-D013-01

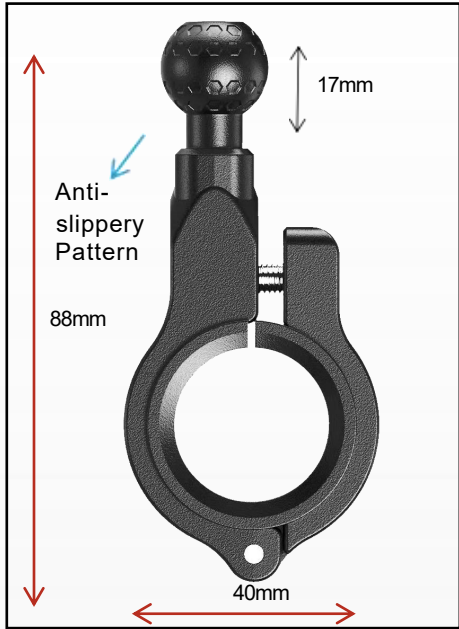

17mm Ball Handlebar

Material: PA66+Stainless Steel
 Color: Black
 Pipe Dia: 1.2-3.3cm

Net Weight: 58g
 Body Size: mm
 Packing: 1pcs/opp bag



Fitting details:

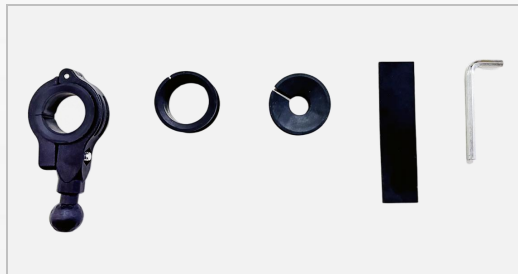

YF-D013-02

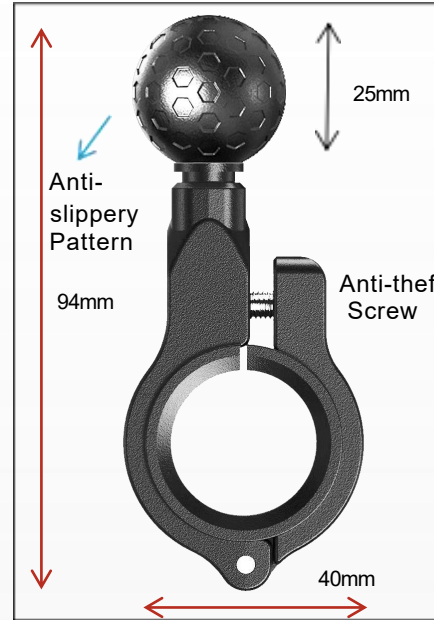

25mm Ball Handlebar

Material: PA66+Stainless Steel
 Color: Black
 Pipe Dia: 1.2-3.3cm

Net Weight: 66g
 Body Size: mm
 Packing: 1pcs/opp bag

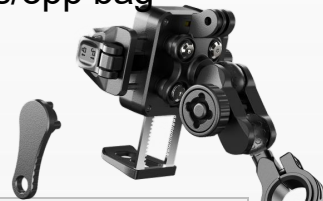

Fitting details:

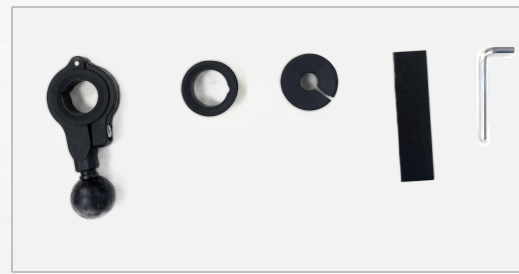

Accessory Introduction: Aluminum CNC Mirror bar

PJ-001C-02



17mm CNC Extensionbar

Material: 6061 Aluminum alloy + TPU
 Clampable pipe diameter: 8-16mm
 Treatment: Sandblasting + Anodized

Net Weight: 35g
 Size:
 Packing: 1pcs/opp bag

PJ-001C-02



25mm CNC Extensionbar

Material: 6061 Aluminum alloy + TPU
 Clampable pipe diameter: 8-16mm
 Treatment: Sandblasting + Anodized

Net Weight: 43g
 Size:
 Packing: 1pcs/opp bag

Fitting details



Anti-slippery Pattern



Fitting details



Accessory Introduction: Ball head Mounting

YF-D003-01



M8 Ballhead

Material: Stainless Steel + TPU
 Color: Black

Net Weight: 37g
 Size:
 Packing: 1pcs/opp bag

YF-D003-02



M10 Ballhead

Material: Stainless Steel + TPU
 Color: Black

Net Weight: 45g
 Size:
 Packing: 1pcs/opp bag

Fittings diagram:



Accessory Introduction: Handlebar Mounting

YF-D004

Die-casting handlebar

Material: Aluminum Alloy + Stainless steel + TPU

Color: Black

Finishing: Powder Painted

Pipe Dia: 1.8-3.3cm

Net Weight: 77g

Size: L*H 52*75mm

Packing: 1pcs/opp bag



Fittings diagram:



YF-D005

Double U handlebar

Material: Aluminum Alloy + Stainless steel + TPU

Color: Black

Finishing: Powder Painted

Pipe Dia: 1.8-3.3cm

Net Weight: 114g

Size: L*H 56*70mm

Packing: 1pcs/opp bag



Fittings diagram:

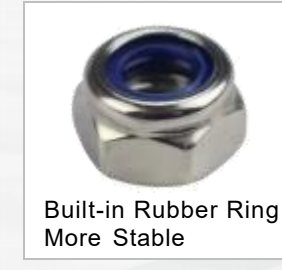

Accessory Introduction: Handlebar Mounting

YF-D006

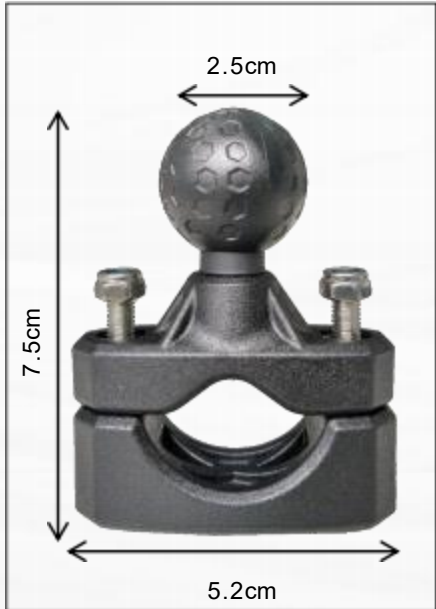

Anti-Theft Screw



Built-in Rubber Ring More Stable

PA66 Handlebar Mounting

Material: PA66+30%GF+Stainless Steel+TPU

Color: Black

Pipe Dia: 1.8-3.3cm

Net Weight: 76g

Size: L*H 52*75mm

Packing: 1pcs/opp bag

YF-D007

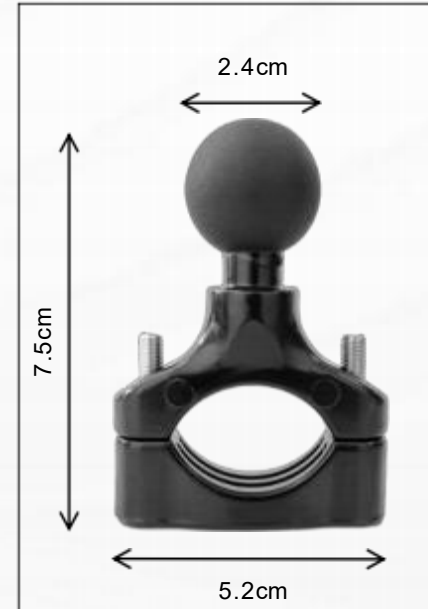

Electrophoretic Handlebar Mounting

Material: Stainless steel + Aluminum Alloy + TPU

Color: Black

Finishing: Electrophoretic

Pipe Dia: 1.8-3.3cm

Net Weight: 74g

Size: L*H 52*75mm

Packing: 1pcs/opp bag

Fittings diagram:



Anti-Slippery Pattern



Fittings diagram:



light-weighted design



Accessory Introduction: PA66 Handlebar Mounting w. Hook

YF-D014-001

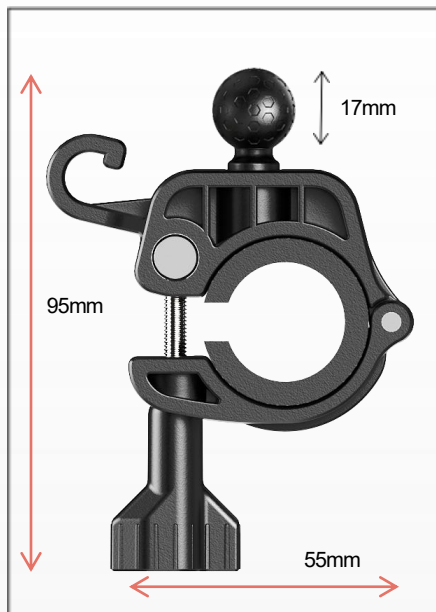

PA66 Handlebar with Hook

Material: PA66+Stainless Steel
Color: Black
Pipe Dia: 1.2-3.3cm
Hook weight: up to 5kg

Net Weight: 67g
Size: mm
Packing: 1pcs/opp bag

Fittings diagram:



Accessory Introduction: Mirrorbase Mounting

YF-D008

Mirrorbase Mounting



Material: Stainless Steel+TPU
 Color: Black
 Finishing: Chrome Plated
 Installation Diameter: 10mm

Net Weight: 52g
 Size: mm
 Packing: 1pcs/opp bag



YF-D009

Mirrorbase Mounting



Material: Sheet Iron + TPU
 Color: Black
 Finishing: Powder Painted
 Installation Diameter: 10mm

Net Weight: 27g
 Size: mm
 Packing: 1pcs/opp bag



YF-D010

Mirrorbase Mounting



Material: Aluminum Alloy + TPU
 Color: Black
 Finishing: Oxidation Bright Black
 Installation Diameter: 10mm

Net Weight: 26g
 Size: mm
 Packing: 1pcs/opp bag

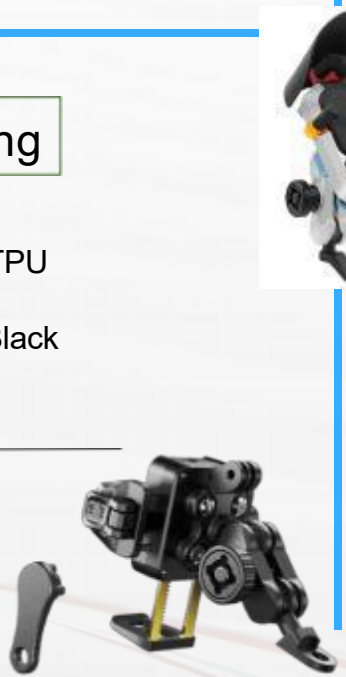

YF-D011

Mirrorbase Mounting



Material: Aluminum Alloy + TPU+Sheet Iron
 Color: Black
 Finishing: Powder Painted
 Installation Diameter: 10mm

Net Weight: 35g
 Size: mm
 Packing: 1pcs/opp bag



Accessory Introduction: PA66 Mirrorbase Mounting

YF-D012



PA66 Mirrorbase Mounting

Material: PA66+30%GF+TPEE+Sheet Iron
 Color: Black
 Installation Diameter: 10mm

Net Weight: 36 g
 Size: mm
 Packing: 1pcs/opp bag



Fittings diagram:



Note:

1. Comparison Shot of YF-D004 and YF-D006
2. Different material, both sturdy and stable
3. Cost difference 3 times



Accessory Introduction: Left and right clip

YF-J001-01

YF-J001-01W



Anti-slippery Pattern



Gold Plated Copper Screw Anti-theft Design

Anti-theft left and right clip

Material: Aluminum Alloy+Stainless Steel + PA66+30%GF

Color: Black / White

Pipe Dia: 1.8-3.3cm

Net Weight: 98g

Size:

Packing: 1pcs/opp bag

Finishing: Powder Painted

Finishing: Painted White

Fittings diagram:



Accessory Introduction: Left and right clip

YF-J001-04

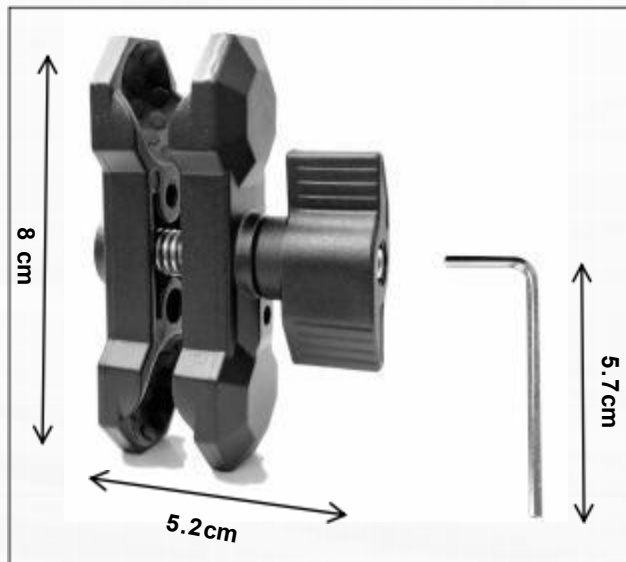

Anti-slippery Pattern

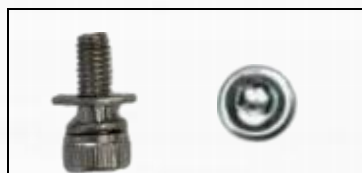

Anti-Theft Screw working only with Allen wrench



Anti-theft left and right clip

Material: Aluminum Alloy+Stainless Steel + PA66+30%GF

Color: Black

Finishing: Powder Painted

Pipe Dia: 1.8-3.3cm

Net Weight: 91g

Size:

Packing: 1pcs/opp bag

Finishing: Powder Painted

Fittings diagram:



Accessory Introduction: Left and right clip

YF-J007

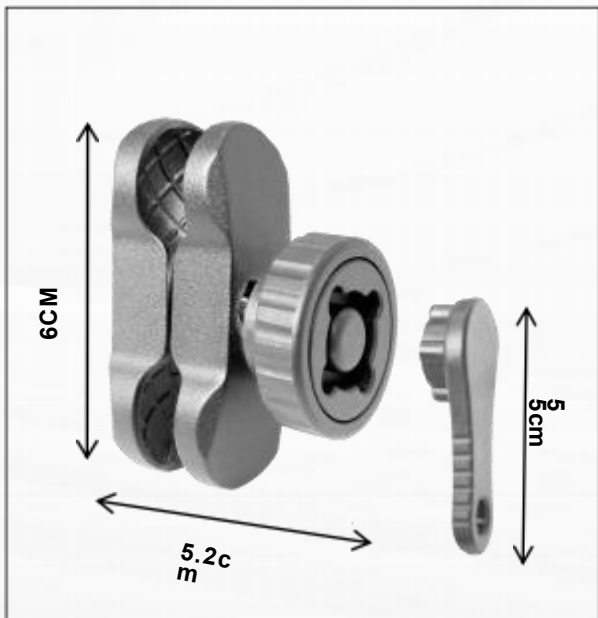

Anti-slippery Pattern



Gold Plated Copper Screw Anti-theft Design

Anti-theft left and right clip

Material: Aluminum Alloy+Stainless Steel + PA66+30%GF

Finishing: Powder Painted

Color: Black

Pipe Dia: 1.8-3.3cm

Net Weight: 63/g

Size: mm

Packing: 1pcs/opp bag

Fittings diagram:



Accessory Introduction: Camera Mount

YF-J002

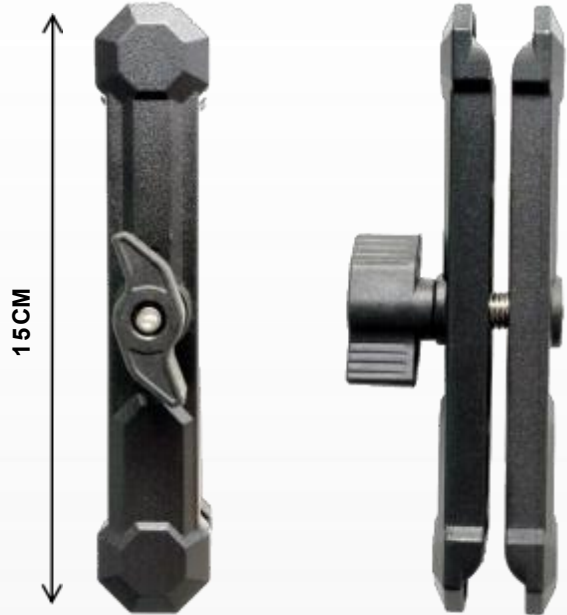

Anti-slippery Pattern

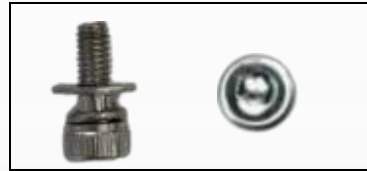

Anti-Theft Screw working only with Allen wrench



Anti-theft Die-casting Camera Mount

Material: Aluminum Alloy+Stainless Steel

Color: Black

Finishing: Powder Painted

Net Weight: 171g (15cm)

Size:

Packing: 1pcs/opp bag

Note: 8cm version J001 is available besides fitting in phone holder



Fittings diagram:



Example: YF-J002 + YF-C001 + YF-D001 = YF-280

YF-J002 + YF-C001 + YF-D010 = YF-280-02



OR



Note: with different mounting devices, cameras can be installed in different places safely

Accessory Introduction: 6cm Metal Left and Right Clip

YF-J003

Left and right clip

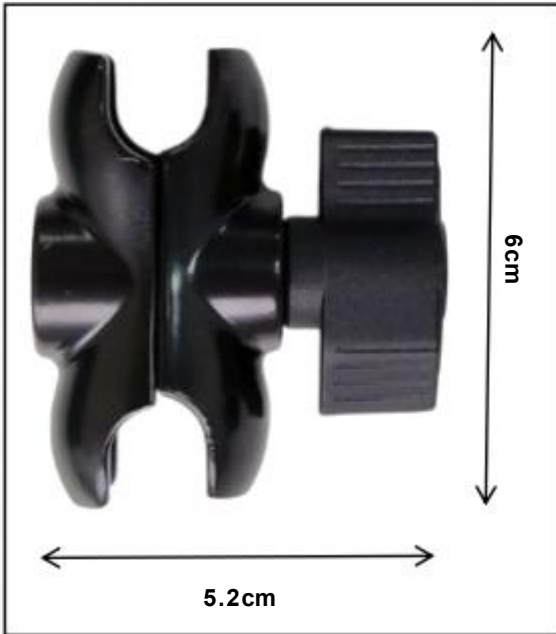

Material: Aluminum Alloy+ PA66 + 30%GF
 Color: Black
 Finishing: Electrophoretic
 Pipe Dia: 1.8-3.3cm

Net Weight: 72g
 Size: mm
 Packing: 1pcs/opp bag



Fittings diagram:



Accessory Introduction: 6cm Metal Left and Right Clip

YF-J004-03

Left and right clip

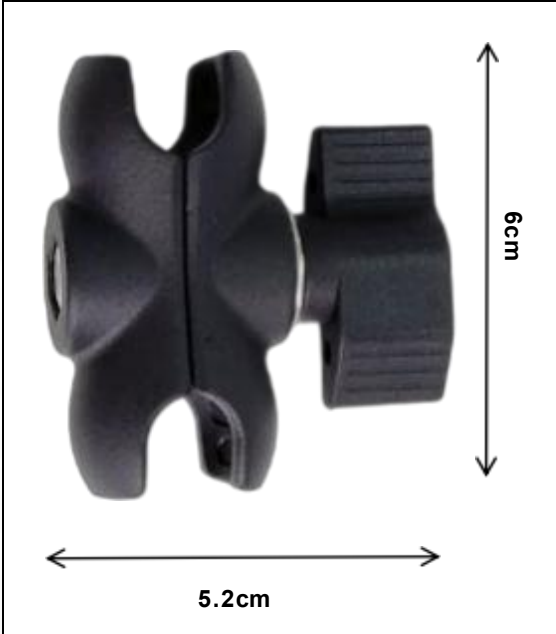

Material: Aluminum Alloy+ PA66 + 30%GF
 Color: Black
 Finishing: Powder Painted
 Pipe Dia: 1.8-3.3cm

Net Weight: 75.7g
 Size: mm
 Packing: 1pcs/opp bag



Fittings diagram:



YF-J004-04

Anti-theft Left and right clip

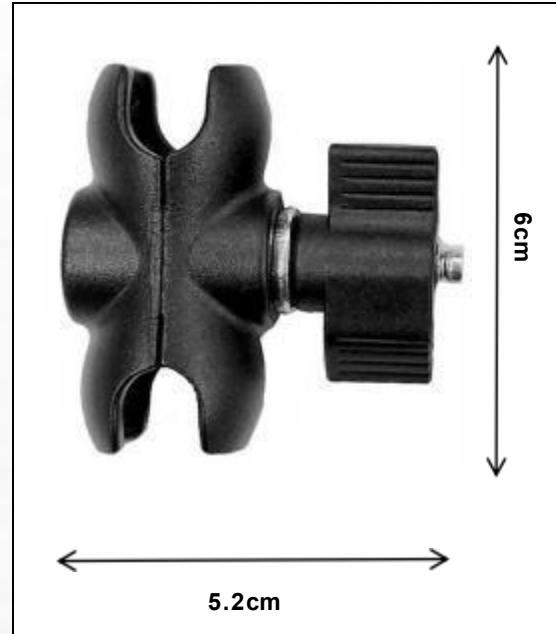

Material: Aluminum Alloy+ PA66 + 30%GF
 Color: Black
 Finishing: Powder Painted
 Pipe Dia: 1.8-3.3cm

Net Weight: 88g
 Size: mm
 Packing: 1pcs/opp bag

Fittings diagram:



Accessory Introduction: 6cm Plastic Left and Right Clip

YF-J005-02

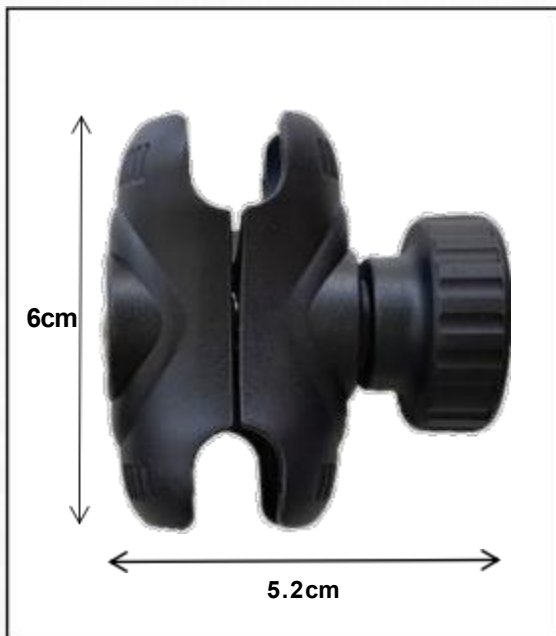

Anti-theft left and right clip

Material: PA66+30%GF+Stainless Steel

Color: Black

Pipe Dia: 1.8-3.3cm

Net Weight: 71g

Size: mm

Packing: 1pcs/opp bag



YF-J005-03

Net Weight: 63g



YF-J005-04 anti-theft

Net Weight: 64g



Fittings diagram:



Note:

1. 02,03,04 share the same body.
2. 02 & 04 are anti-theft version
2. 03 is a regular version



Accessory Introduction: 9cm Plastic Left and Right Clip

YF-J006-03

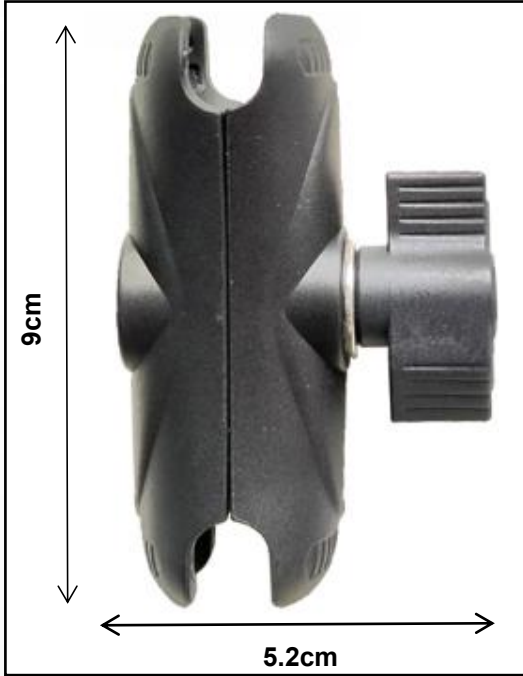

left and right clip

Material: PA66+30%GF+Stainless Steel
Color: Black

Net Weight: 82g
Size: mm

Packing: 1pcs/opp bag

Fitting Diagram



YF-J006-02

NW: 90g



YF-J006-04

NW: 85g



Note:
1. 02,03,04 share the same body.
2. 02 & 04 are anti-theft version
3. 03 is a regular version

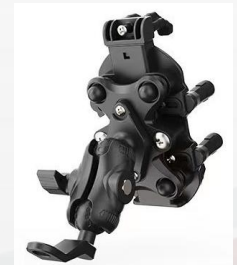

Accessory Introduction: Camera Mount

YF-C001



25mm Ball Camera Mount

Material: Aluminum Alloy+Stainless Steel+PA66+30%GF
 Color: Black

Net Weight: 44g
 Size:
 Packing: 1pcs/opp bag

Fittings diagram:

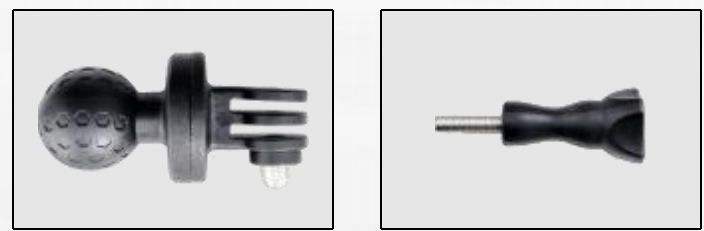

Example: YF-J004 + YF-J016 + YF-J001 = YF-280



Accessory Introduction: Handlebar to Mirrorbase Converter

YF-V001

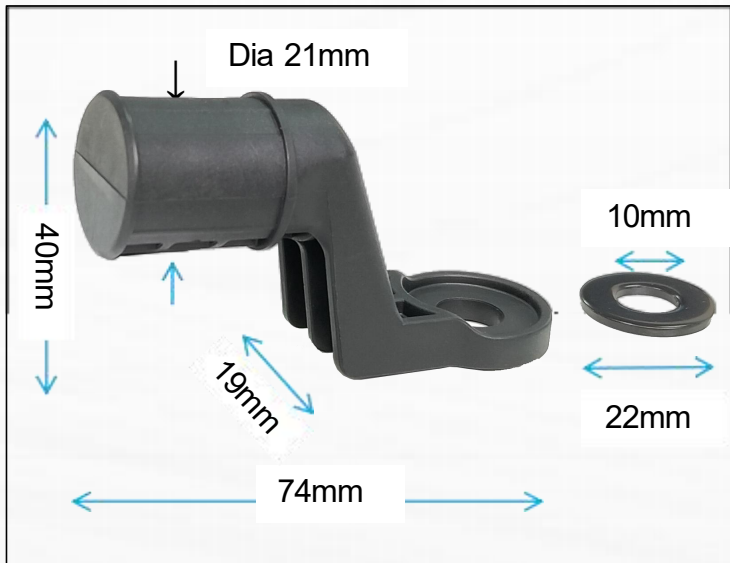

Reduced Weight Slim Design



Premium Stainless Steel Washer

Handlebar to Mirrorbase Converter Mount

Material: PP+10%GF

Color: Black

Pipe Outer Dia: 21mm

Net Weight: 24g

Size:

Packing: 1pcs/opp bag

Fittings diagram:

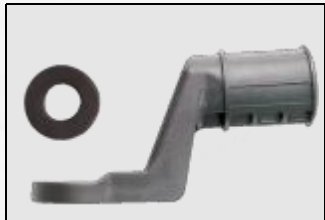

Example: Together with YF-286



1. Handlebar installation
2. With Converter Mount
3. Final mounting on mirrorbase

Application: Motorcycle, Bicycle, Tricycle, Electric Vehicles, Bicycles





THANK YOU

东莞市科拓电子科技有限公司

Dong Guan Ketuo Electronic Technology Co., Ltd.

地址:广东省东莞市常平镇环城路珠宝产业园第七栋

联系: 邹小姐 手机/微信: 133 1665 1228

Email: sales1@dgketop.com

Website: www.dgketuo.com

Add: Building 7, Jewelry Industry Park, Huancheng Road,
Changping Town, Dongguan City, Guangdong Province

Contact: Anna Zou Mob/Wechat: +86 133 1665 1228

Email: sales1@dgketop.com

Website: www.dgketuo.com